

Lindab **Modular Air Handling Units**

Technical Catalogue

Content

Lindab Modular Air Handling Units

General characteristics	4	Electric heater	21
• Description	4	Indirect gas heater	21
Types and application areas	6	• Humidification section	22
• Indoor air handling units	6	Spray humidifier	22
• Outdoor air handling units	6	Steam humidifier	23
• Swimming pool air handling units	7	Honeycomb humidifier	23
• Hygienic air handling units	8	High-pressure humidifier	26
• Explosion-proof air handling units	8	• Cooling section	28
Examples of typical configurations	9	Water cooler	28
Ordering key	11	Water cooler with droplet eliminator	28
Selection software	11	Direct evaporator (DX cooler)	29
Sizes and dimensions	12	Siphon	30
• Cross section dimensions	12	• Compressor section	30
• Size specification table	12	• Filter section	31
Functional units	13	Panel filter	31
• Designations overview	13	Bag filter	31
• Fan section	17	Metal filter	32
Plug fan with an EC motor	17	Activated carbon filter	33
Plug fan with an AC motor	17	High-efficiency filter	33
Direct-driven fan with a spiral housing	17	• Sound attenuation section	34
Belt-driven fan	18	• Heat recovery section	34
• Heating section	18	Run-around coil	34
Water heater	19	Cross-flow plate heat exchanger	36
Frost protection	19	Double plate cross-flow heat exchanger	36
Steam heater	20	Counter-flow heat exchanger	37
Condenser	20	Rotary heat exchanger	37
		Heat pump	38
		Controls	39

General characteristics



Description

Modular air handling units are intended for central preparation of air and offer all essential functions, including heating, cooling, filtration, humidification, dehumidification, heat recovery, and regeneration.

They feature outstanding flexibility due to the adjustable modular construction, availability of 43 standard sizes with air volume flow rates ranging from 1.000 up to 100.000 m³/h, and a customized selection of high-efficiency functional elements.

Among the distinctive features is easy installation due to a solid housing and adaptability to the building entrance conditions, as well as simplicity of interconnection into a set inside or outside the housing.

Air handling units can be dismantled into any number of compact sets, depending on the number of functional sections, unit size, transport options, and building requirements.

We can offer a package solution of an air handling unit with an integrated cooling system and control systems. Air handling units can be fitted with all the control equipment required for automatic operation. We can also manage the start-up of the unit and train the maintenance personnel for proper unit handling.

Application

- Indoor version (KNN)
- Outdoor version (KZN)
- AHU for swimming pools (KBN)
- Hygienic AHU (KHN)
- ATEX (KXN)

Quality & Certificates

High and constant quality of the manufacturing process and products is our priority. Lindab air handling units conform to the following standards and directives:

- ISO 9001:2015
- Eurovent certificate for the Klimair2 range. Tests of mechanical characteristics and air flow rates were performed according to EN 1886 and EN 13053.
- Hygienic air handling units conform to DIN 1946-4, EN 13053 and VDI 6022-1.
- ErP 2018 Directive – detailed info on requirements is stated in a separate brochure.
- European directive for machinery, low voltage and electromagnetic compatibility.
- Explosion-proof models are made in conformity with the Directive 2014/34/EU, ATEX certificate.

Housing types

The housing of Lindab air handling units features high mechanical stability and low energy consumption, combined with a low risk of housing condensation due to the high quality of thermal insulation and air-tightness of the housing. Acoustic and thermal insulation is made of 50 mm thick mineral wool, glued to the panels, with fibres oriented perpendicular to the wall surface. It is non-flammable and it remains stable over time. Internal surfaces are flat and smooth.

Within the **Klimair2 housing family**, two housing types are available:



TopAir Plus

- An energy-efficient housing with improved thermal bridges and a thermal transmittance class suitable for demanding applications.

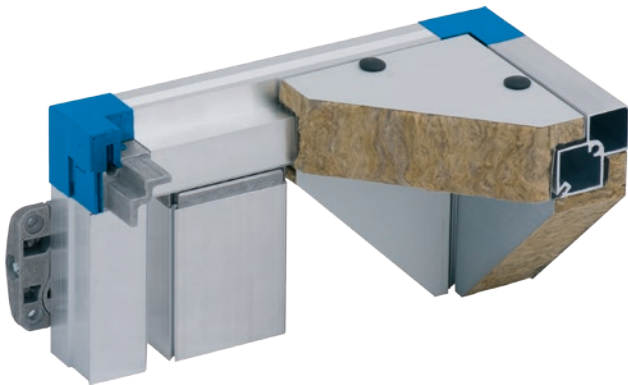

TopAir

- The standard housing, fulfilling most project demands.

Housing characteristics	Klimair2/ TopAir Plus	Klimair2/ TopAir
Mechanical stability	D1	D1
Leakage	L1	L3
Thermal transmittance	T2	T2
Thermal bridging	TB2	TB3

Additional anticorrosion powder-coating or use of stainless materials ensure extended service life. Any combination of steel sheet materials is available, such as:

- Galvanized sheet steel
- Powder-coated sheet steel RAL 7035
- Aluzinc

- Stainless steel AISI 304
- Peraluman

Several standard set-up and assembly options are available to suit individual building characteristics:

- Horizontal air handling units [L]
- Two-stage air handling units [D]
- Parallel air handling units [V]
- Vertical air handling units [S]
- Combined air handling units [K]

Customized solutions are available on request.

Heat recovery systems

Select an optimal recovery system:

- Run-around coil
- Cross-flow plate heat exchanger
- Double plate cross-flow heat exchanger
- Counter-flow heat exchanger
- Rotary heat exchanger
- Heat pump

Panels & doors

Top, bottom and side cover panels as well as doors are made of 50 mm double walls, with the inner and outer walls consisting of steel sheet and a mineral wool thermal insulation filler with a density of 90 kg/m³.

As the mineral wool is glued to the panel, it also has a supporting function, ensuring quality concerning not only thermal and sound insulation but also stability. Thermal break aluminium profiles effectively prevent unfavourable thermal bridging on the housing.

Flammability class

The side, bottom and top walls, and the doors complies with class A1 according to EN 13501-1, which stands for non-combustible materials.

Filter leakage

Filter leakage complies with class F9 according to EN 1886.

Thermal stability

The upper limit of the air handling unit thermal stability range is +80 °C – on account of the components sensitive

to high temperatures, such as fan bearings, drive belts, the filter medium, gaskets, etc. For temperatures exceeding +40°C, enhanced insulation electric motors should be installed.

Casing acoustical insulation

	125 Hz	250 Hz	500 Hz	1000 Hz	2000 Hz	4000 Hz	8000 Hz
Klimair2/TopAir	12	10	10	16	25	33	43
Klimair2/TopAir plus	14	13	13	17	25	36	45

Air handling unit types and application areas

Indoor air handling units - KNN

The indoor KNN air handling unit is the most frequently used version. Pipes and other connections, as well as control elements, are placed on the outer side of the unit's housing.



Outdoor air handling units – KZN

The KZN outdoor air handling unit is made of powder-coated steel sheet; it has a protective roof, special protection hoods and grids at the supply air inlet and the exhaust air outlet. Connections and control elements are installed inside the unit.



Swimming pool air handling units – KBN

Air handling units for indoor swimming pools ensure suitable temperature and humidity control regimes according to water operation, visitors' activity, outside air conditions and optimal energy consumption. Its main characteristics are:

- Anti-corrosion materials / epoxy coating
- High-efficiency of heat recovery
- Energy-efficient heat pumps
- A dehumidification function
- An integrated cooling circuit with a scroll compressor
- All necessary control and safety equipment included
- Supply and exhaust fans with a variable-frequency electric motor drive or with EC motors
- Control system: temperature and humidity regulation with the DDC control system



Standard operation regimes:

- operation without dehumidification when the swimming pool is out of use
- operation with dehumidification when the pool is out of use; the heat pump is operating
- operation with or without dehumidification when the pool is in use; the heat pump is operating
- operation during seasonal transitions without dehumidification; the heat pump is operating
- operation in summer with high outside temperatures; the heat pump is not operating

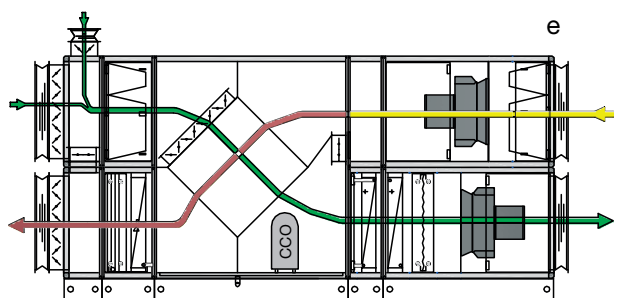
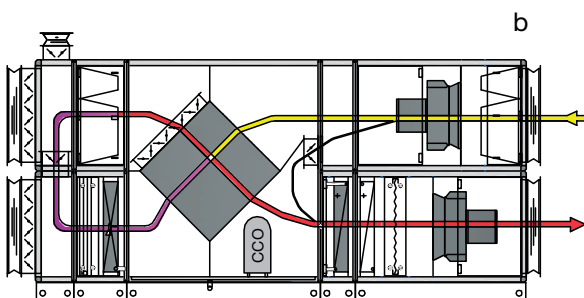
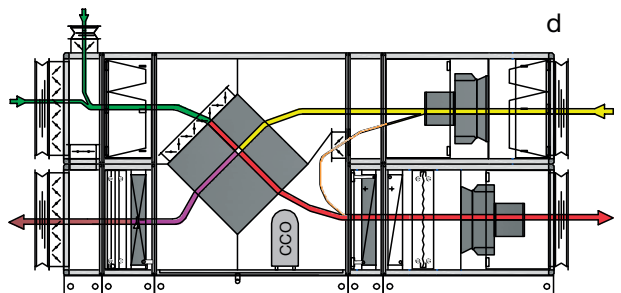
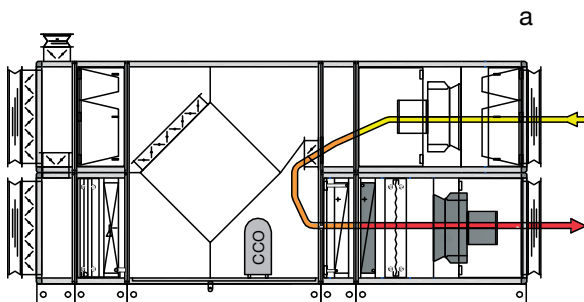
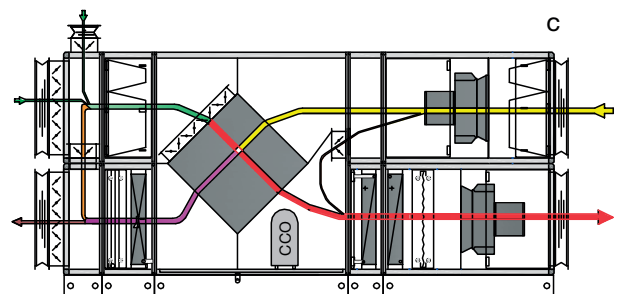

Hygienic air handling units – KHN

Hygienic air handling units (KHN) are used in hospitals, in the food and pharmaceutical industries, and in other clean room applications. Main features:

- Construction without grooves and sharp edges.
- All functional elements (fans, coils, heat recovery units, humidifiers ...) are easily removable for maintenance, cleaning, and service.
- All elements are resistant to corrosion.
- All components and materials are resistant to disinfectants.
- Seals are smooth, abrasion-resistant, closed-pore.
- Build-in components are tested and recognised as effective per the list of the Robert Koch Institute (RKI) or the disinfectant media list of the Association for Applied Hygiene (VAH).
- The internal panels of the housing are made of painted sheet steel, while the bottom is made of stainless sheet steel AISI 304. On special request, the internal panels are available in stainless sheet steel AISI 316.
- All external panels are made of galvanised sheet steel, while all the joints between the frame and the panels are sealed with a clean room application putty.
- Filter classes acc. to ISO 16890
 - ISO ePM10 >50%: pollen
 - ISO ePM2.5 >50%: bacteria, fungal, mold spores
 - ISO ePM1 >50%: viruses, nanoparticles, exhaust gases
- High-efficiency filters (acc. to EN1822): E11, E12, H13, H14
- The units feature plug-in high-efficiency fans, epoxy coated coil frame and fins, a highly efficient run-around coil system and dampers for increased tightness requirements (class 4 according to EN 1751).
- Sound attenuators are made of abrasion-resistant and waterproof material.



Explosion-proof air handling units

Explosion-proof air handling units correspond to the following categories:

- Equipment group II
- Equipment category 2 and 3
- Explosive atmosphere, caused by gases and vapours (G)
- Temperature classes T1, T2, T3, T4 (ignition temperature $T > +135$ °C)
- Protection based on the ATEX Directive 2014/34/EU

Example of designation:



Examples of typical configurations

An air handling unit for heating and cooling with a rotary heat exchanger

Supply: Filter, rotary heat exchanger, heating coil, cooling coil, fan

Exhaust: Filter, fan, rotary heat exchanger

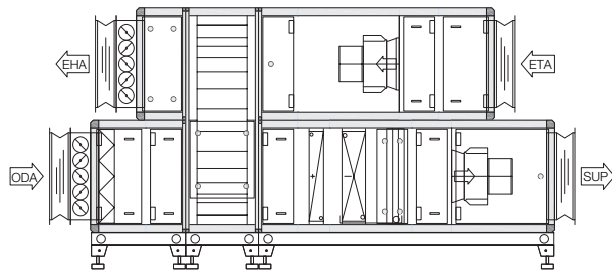

An air handling unit for heating and cooling with a rotary heat exchanger and an integrated cooling system

Supply: Filter, rotary heat exchanger, compressor, evaporator, heating coil, fan

Exhaust: Filter, fan, rotary heat exchanger, condenser

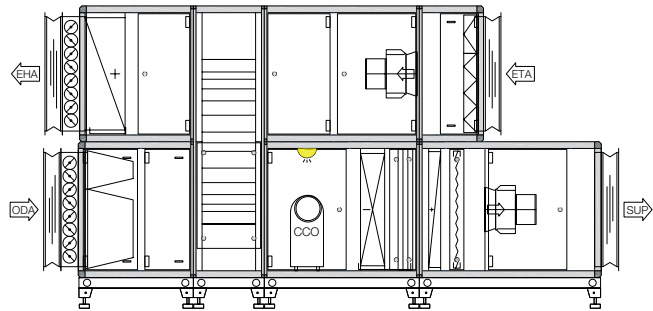

An air handling unit for heating and cooling with a plate heat exchanger

Supply: Filter, counter-flow plate heat exchanger, heating coil, cooling coil, steam humidifier, fan

Exhaust: Filter, fan, plate heat exchanger

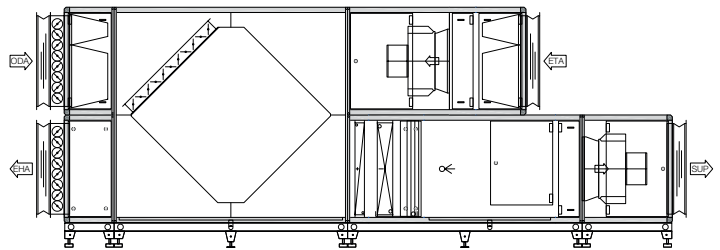

An air handling unit for swimming pools

Supply: Mixing section, filter, plate heat exchanger (cross-flow), circulation section, compressor, condenser, heating coil, fan

Exhaust: Filter, fan, circulation section, plate heat exchanger, evaporator, mixing section

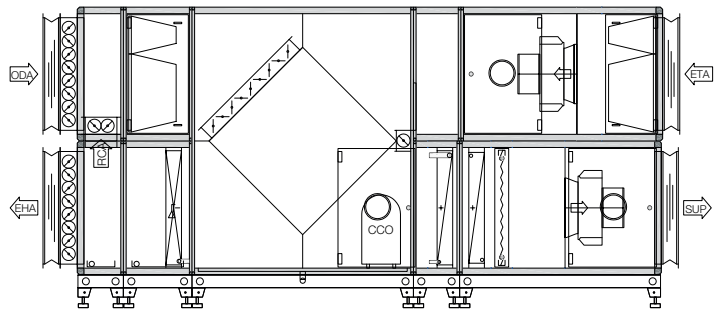

An air handling unit with a plate heat exchanger, an integrated cooling system and heating

Supply: Filter, cross-flow plate heat exchanger, compressor, evaporator, heating coil, fan

Exhaust: Filter, fan, plate heat exchanger, condenser

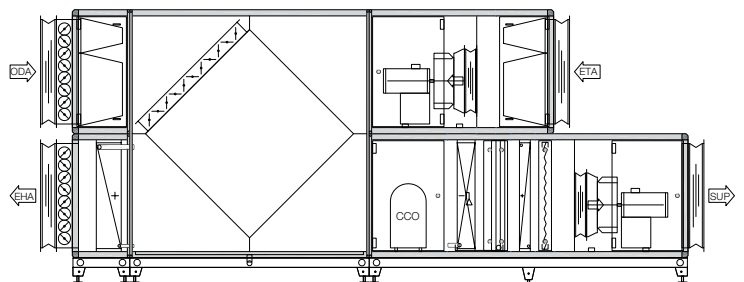

An air handling unit for heating and cooling with a run-around coil

Supply: Filter, run-around glycol heater, heating coil, cooling coil, fan

Exhaust: Filter, fan, run-around glycol cooler

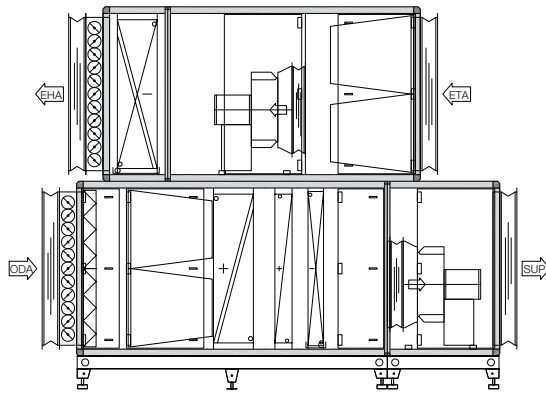

An air handling unit with adiabatic cooling and a double plate heat exchanger

Supply: Filter, circulation section, fan, double-plate heat exchanger, compressor, evaporator, heating coil, filter

Exhaust: Filter, adiabatic cooling, double-plate heat exchanger, condenser, circulation section, fan

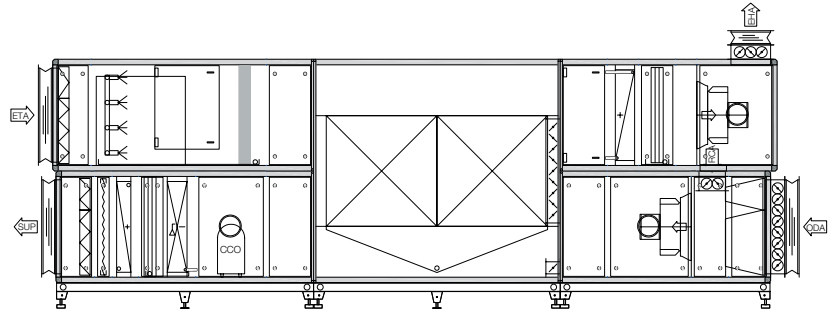

Ordering key example

The ordering key is generated in the selection program.

Ordering key example

KNND d50 12/9 – FK, RPD, VF, KD, TA, L, EE, L, FTT * 12/6 FK, L, VF, RPD, L**

K	air handling unit
N	indoor type
Z	outdoor type
H	hygienic type
B	pool type
X	ATEX type
N	unit design
L	horizontal
D	two-stage
V	parallel
S	vertical
K	combined
d50	panel thickness 50 mm
	cross-section dimension: width / height (example: 12/9)
	functional sections in the direction of the air flow (supply first) – see designations in the chapter “Functional units”

If selecting a bidirectional (supply-exhaust) unit, the sections for the supply side and exhaust side are separated with ***

Selection software

The AirCalc++ selection software is an efficient tool for designers and engineers, allowing precise definition of an air handling unit including indicating the energy class and conformity to the Ecodesign directive. After the calculation is completed, the following print-outs are available:

- Technical specification
- Drawing (in PDF or dwg format)
- Project description
- Process outline in an h-x diagram
- Fan noise curve
- Sound characteristics
- Spare parts list

AirCalc++ also offers a standard configuration library module for a quick selection of modular air handling units.

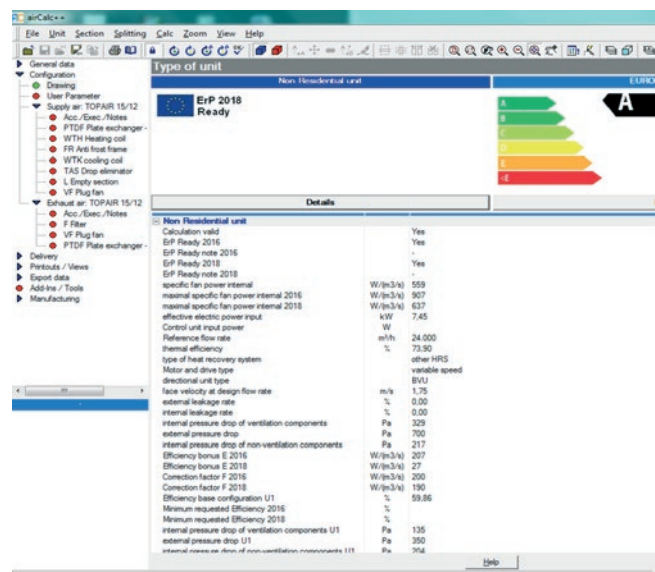

Sizes and dimensions

Cross-section dimensions

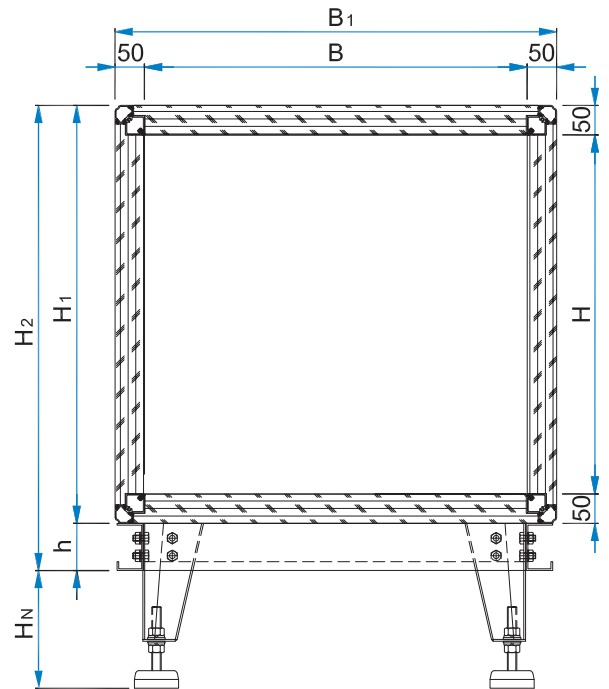

Size specification table



Size	B [mm]	H [mm]	B1 [mm]	H1 [mm]	h [mm]*	H2 [mm]	Aef [m2]
6/3	650	305	750	405	80	485	0.20
9/3	955	305	1055	405	80	485	0.29
6/5	650	510	750	610	80	690	0.33
6/6	650	610	750	710	80	790	0.40
9/6	955	610	1055	710	80	790	0.58
12/6	1260	610	1360	710	80	790	0.77
6/9	650	915	750	1015	80	1095	0.59
9/9	955	915	1055	1015	80	1095	0.87
12/9	1260	915	1360	1015	80	1095	1.15
15/9	1565	915	1665	1015	80	1095	1.43
18/9	1870	915	1970	1015	80	1095	1.71
21/9	2175	915	2275	1015	100	1115	1.99
9/12	955	1220	1055	1320	80	1400	1.17
12/12	1260	1220	1360	1320	80	1400	1.54
15/12	1565	1220	1665	1320	100	1420	1.91
18/12	1870	1220	1970	1320	100	1420	2.28
21/12	2175	1220	2275	1320	100	1420	2.65
24/12	2480	1220	2580	1320	100	1420	3.03
27/12	2785	1220	2885	1320	100	1420	3.40
12/15	1260	1525	1360	1625	100	1725	1.92
15/15	1565	1525	1665	1625	100	1725	2.39
18/15	1870	1525	1970	1625	100	1725	2.85
21/15	2175	1525	2275	1625	100	1725	3.32





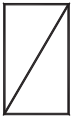

24/15	2480	1525	2580	1625	100	1725	3.78
30/15	3090	1525	3190	1625	100	1725	4.71
15/18	1565	1830	1665	1930	100	2030	2.86
18/18	1870	1830	1970	1930	100	2030	3.42
21/18	2175	1830	2275	1930	100	2030	3.98
24/18	2480	1830	2580	1930	100	2030	4.54
27/18	2785	1830	2885	1930	100	2030	5.10
18/21	1870	2135	1970	2235	100	2335	3.99
21/21	2175	2135	2275	2235	100	2335	4.64
24/21	2480	2135	2580	2235	100	2335	5.29
27/21	2785	2135	2885	2235	100	2335	5.95
30/21	3090	2135	3190	2235	100	2335	6.60
21/24	2175	2440	2275	2540	100	2640	5.31
24/24	2480	2440	2580	2540	100	2640	6.05
27/24	2785	2440	2885	2540	100	2640	6.80
30/24	3090	2440	3190	2540	100	2640	7.54
36/24	3395	2440	3495	2540	100	2640	8.28
24/27	2480	2745	2580	2845	100	2945	6.81
27/27	2785	2745	2885	2845	100	2945	7.64
30/27	3090	2745	3190	2845	100	2945	8.48



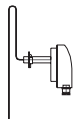
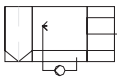
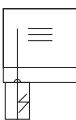

* Note: possibility to choose h=200mm

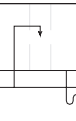
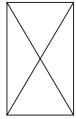
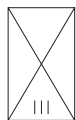
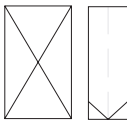
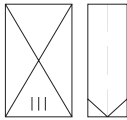
Functional units

Designations overview

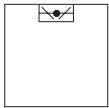
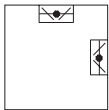
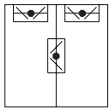
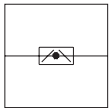
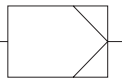
Symbol / label on AHU unit	Section designation	Section description
	VF VD VR	Fan section – plug fan Fan section – direct driven fan Fan section – belt driven fan
	EW	Heating section with a water heater
	ED	Heating section with a steam heater
	EK	Heating section with a condenser

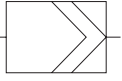
	EE	Heating section with an electric heater
	EGI	Heating section with an indirect gas heater
	FR	Anti-freezing protection section
	BLW	Humidification section with a spray humidifier Humidification section with a high-pressure humidifier
	BD	Humidification section with a steam humidifier with an electric steam generator
	BD	Humidification section with a steam humidifier with an outside steam section
	BWA	Humidification section with a contact humidifier
	KW	Cooling section with a water cooler
	KD	Cooling section with a direct evaporator (DX)
	KW-TA	Cooling section with a water cooler – with a droplet eliminator
	KD-TA	Cooling section with a direct evaporator – with a droplet eliminator
	TA	Droplet eliminator
	KO	Compressor section

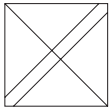
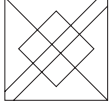
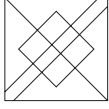
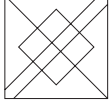
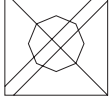
	A	Intake section – with a single control damper
	M	Mixing section – with two control dampers
	MD	Dual mixing section – with three control dampers
	U	Circulation section
	FK FT FTT FM	Panel filter section Bag filter section Bag filter section – model with door Metal grease filter section
	FAK	Activated carbon filter section
	FA	High-efficiency filter section
	S	Sound attenuation section
	LU	Empty angle section
	RKE RKK RKK-TA	Recuperation section with a run-around coil Heating part Cooling part Cooling part with a droplet eliminator
	RPD	Recuperation section with a cross-flow plate heat exchanger (diagonal design)
	RPDC	Recuperation section with a counter-flow plate heat exchanger
	RPDB	Recuperation section with a double plate cross-flow heat exchanger
	RRG	Recuperation section with a rotary heat exchanger

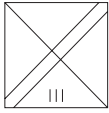
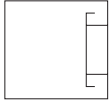
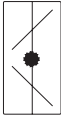
	RWR	Recuperation section with a heat pipe
	D	Diffuser section
	J	Control damper
	ST	Flexible connection
	H	Protection hood
	WSG	Protection grille
	EEJ	Control damper electric heater

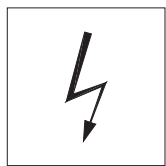

Electric control cabinet section

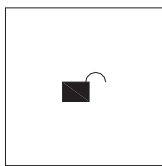

Handle position open

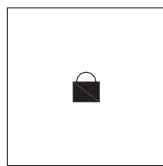

Handle position closed

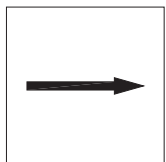

Air direction medium direction

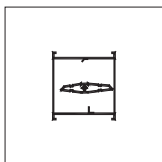

Control damper open

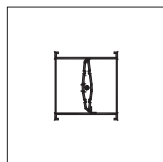

Control damper closed

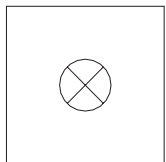

Medium entry red colour

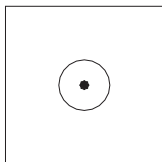

Medium exit blue colour

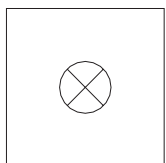

Medium entry blue colour

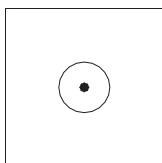

Medium exit red colour

Negative pressure siphon - side connection:

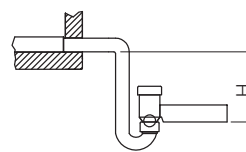

Positive pressure siphon - side connection:

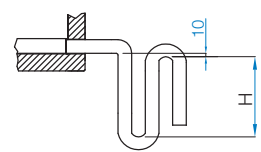

Negative pressure siphon - bottom connection:

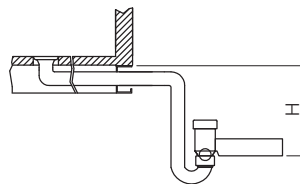

Positive pressure siphon - bottom connection:

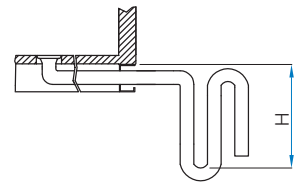

Section total pressure [Pa]	H [mm] - Positive/negative pressure
300	40
600	75
900	110
1200	140
1500	175
1800	210
2100	240

Fan section

Fan options available:

- Plug fan with an EC motor
- Plug fan with an AC motor
- Direct-driven fan with a spiral housing
- Belt-driven fan with a spiral housing

Plug fan with an EC motor – VF

The plug fan is equipped with an electronically commutated motor (EC) and integrated electronics in the motor housing; consequently no frequency controller is needed.

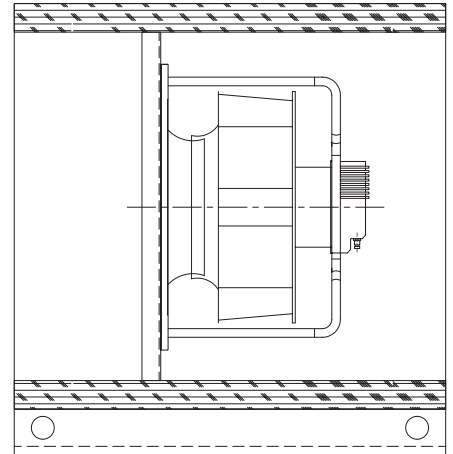

Plug fan with an AC motor - VF

An electric motor directly drives this fan via its shaft which is mounted on the fan frame via a base plate. The fan structural frame is fixed to the unit housing through vibration insulators. A flexible duct connection prevents fan pressure flange vibrations from transferring to the unit housing.

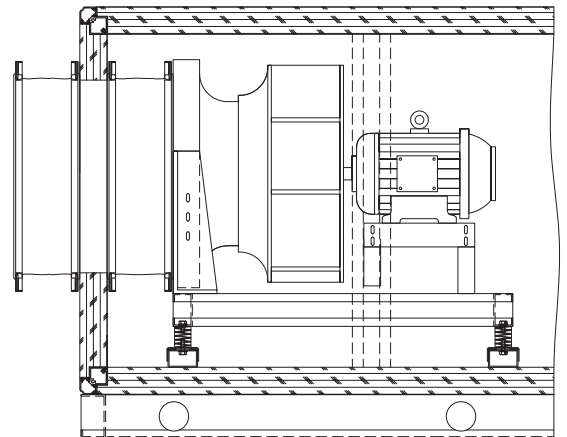

Direct-driven fan with a spiral housing – VD

Double inlet fan with direct drive by coupling.
Fan with a directly coupled motor fitted on a pedestal and base frame. Max. medium temperature +40 °C.
The fan structural frame is mounted on the unit housing through vibration insulators. The flexible duct connection prevents the transfer of fan pressure flange vibrations to the unit housing.

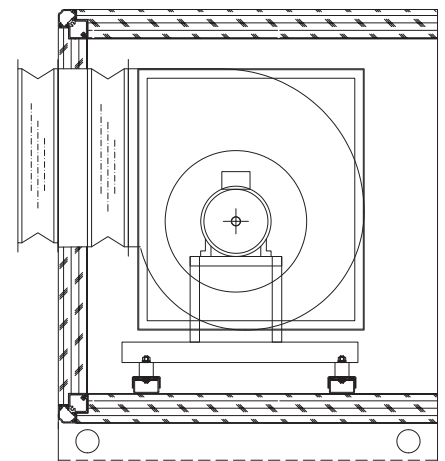

Belt-driven fan - VR

The fan is mounted on the structural frame on a tensioning plate with an electric motor, which allows correction of the belt's tension. The electric motor drives the fan via V-belts and pulleys. The fan structural frame is mounted on the unit housing through vibration insulators. The flexible duct connection prevents the transfer of fan pressure flange vibrations to the unit housing. The fan drive electric motors are classified as insulation class F. It is intended for air streams with temperatures ranging from -30°C up to $+55^{\circ}\text{C}$.

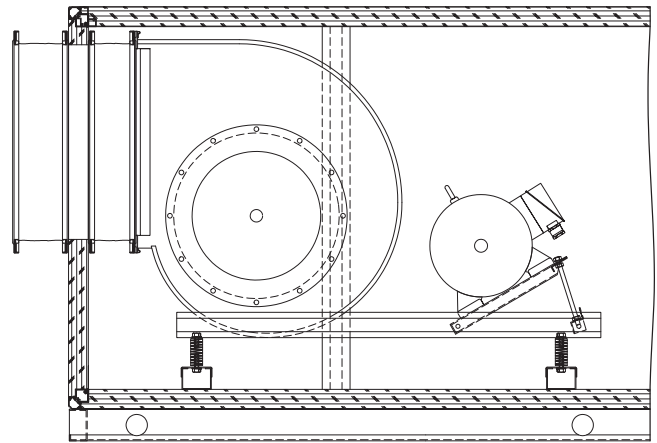

Belt driven fan - horizontal design
Belt driven fan - vertical design

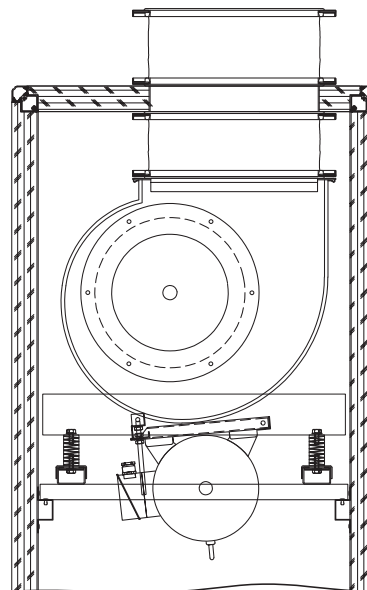

Heating section

Heat exchangers are used for heating and cooling air with different media (water, steam). They are designed for installation in air handling units or air ducts. Heat exchangers are used in:

- Water heaters (type GV)
- Steam heaters (type GP)
- Condensers (type KF)
- Electric heaters
- Indirect gas heaters

Heating section with a water heater – EW

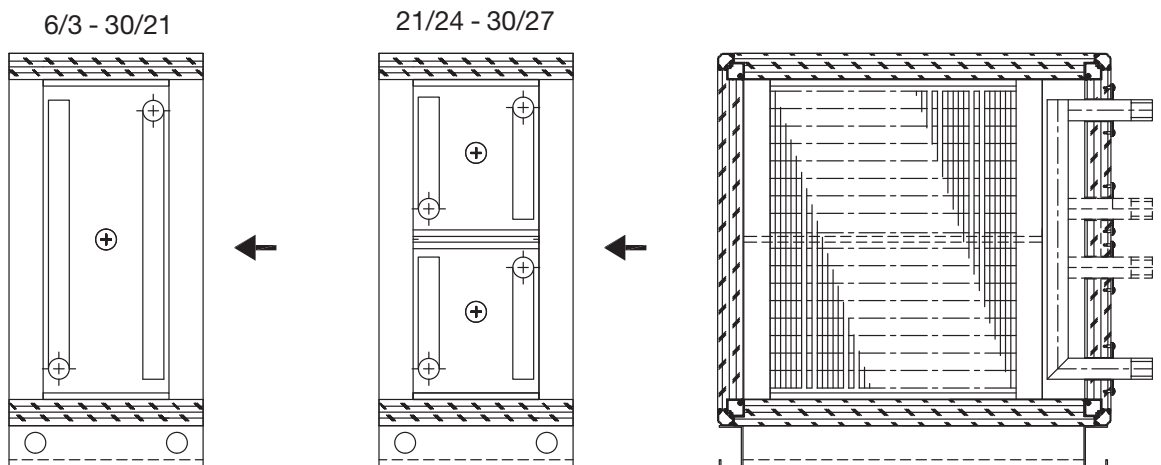

The fin package of the water heater consists of copper tubes and aluminium fins. The collection and distribution pipes are fitted with an air-bleed and drain valve. The collection pipe, distribution pipe, and solder joints are protected against corrosion with a temperature-resistant

coating. Every water heater is tested for tightness at a pressure level corresponding to the operating pressure. If the water heater has a pre-heating function, the anti-freeze protection section can be placed either on the air or water side. The water heater is mounted on removable guides.

Section with frost protection: FR

The frost protection can be installed on the water side or the air side. If controls are supplied by Lindab, the frost protection regulation is already provided. In other cases, only a frame for the installation of a capillary tube is prepared for the air side option. For the water side option, a connection for the temperature sensor is mounted in the heat exchanger at the factory.

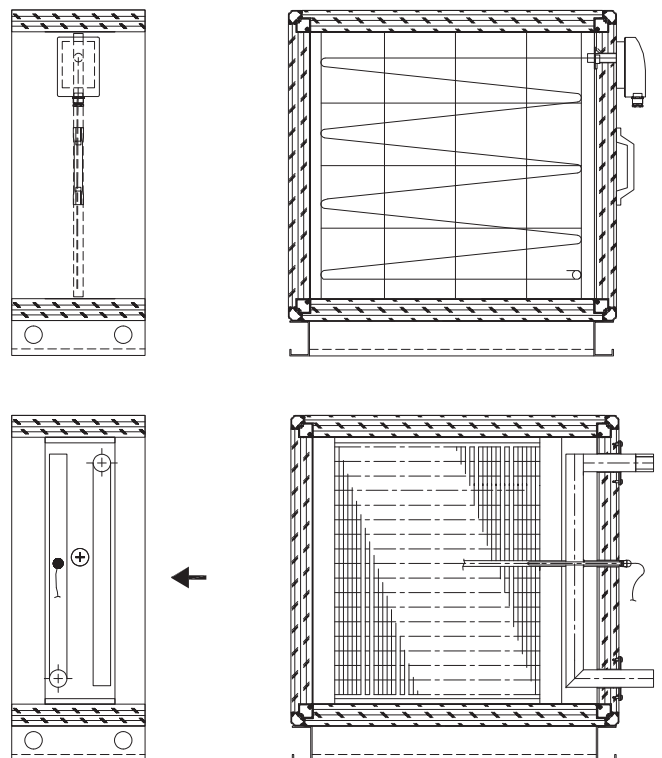

Heating section with a steam heater: ED

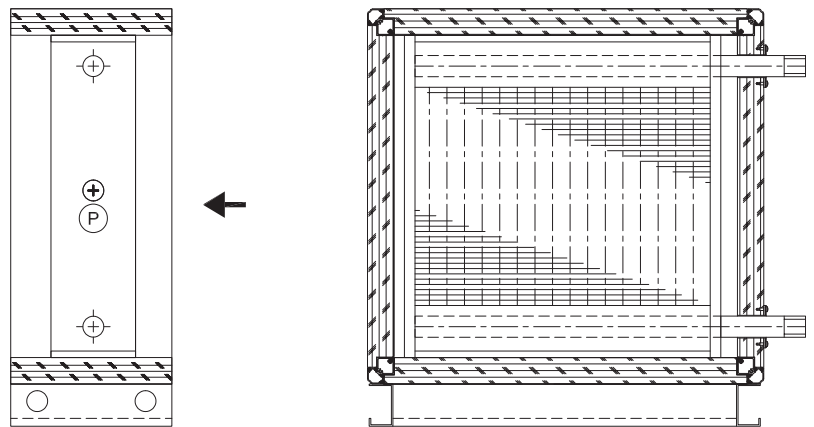

The steam heater consists of a frame and an aluminium fin package with copper pipes, collection pipes and distribution pipes. Aluminium fins and copper pipes are joined through mechanical expansion.

The collection and distribution pipes, which interconnect the copper pipes, are made of steel and are fitted with a thread or flange connection and an air-bleed and drain valve.

The steam heater frame protects pipe elbows and is used

to mount the heater in the unit. The water heater is fitted into the housing through guides allowing easier removal. The collection pipe, distribution pipe, and solder joints are protected against corrosion with a temperature resistant coating.

Steam heater (GP type): working medium steam, utilizing only saturated steam condensation heat. Serviceable up to 9 bar maximum.

The steam heater is mounted on removable guides.

Heating section with a condenser: EK

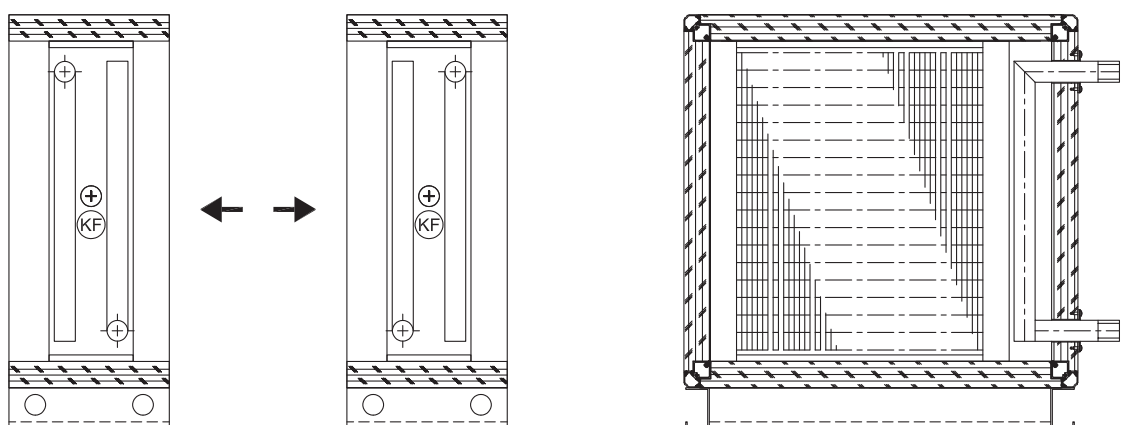

A heating section with a condenser is a part of the integrated cooling system.

The condenser heats the air through a Freon-based agent R410a and R407c. If required, a condenser can be divided

into two or more cooling circuits.

The condenser is mounted in the housing using guides allowing its removal in case of defect or damage.

Heating section with an electric heater: EE

An electric heater section consists of the section housing, an electric air heater, and a two-stage protection thermostat. The electric heater is mounted in the housing using guides allowing its removal in case of defect or damage.

Selection guidelines: EE

- Airflow velocity through the electric air heater should not be less than 1.5 m/s.
- Functional sections with temperature-sensitive components should be separated from the electric heater section with an empty section no less than 650 mm long.
- If the electric air heater section is installed downstream of the fan section (the fan blowing into the heater), there

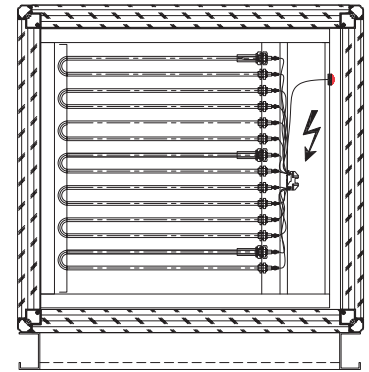
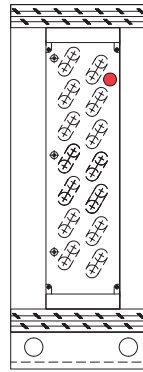

should be an empty section, (with a length of

$$L = (H+B)/2$$

H = air handling unit height,

B = width – but in no case less than 600 mm) installed between the two.

Heating section with an indirect gas heater: EGI

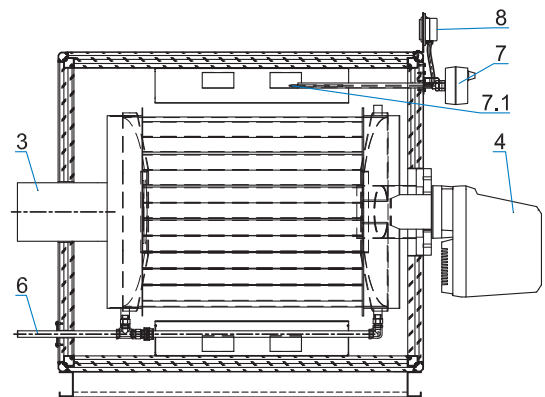
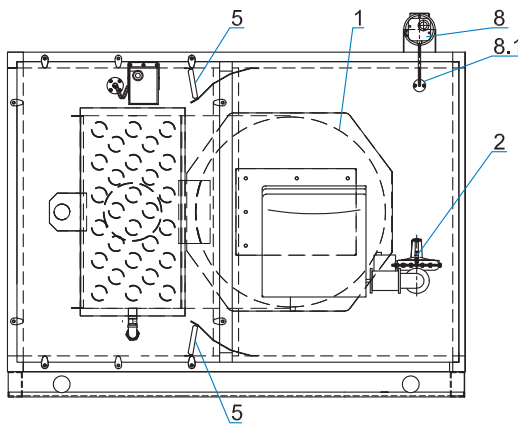

1. Combustion chamber
2. Gas train
3. Flue pipe
4. Gas burner with continuous (stepless) control of the heating power
5. Top-to-heater and bottom-to-heater air-directing baffle

6. Condensate drain
7. Safety thermostat – set to 80 °C – and security temperature sensor – set to 90 °C
- 7.1. Safety thermostats and security temperature sensor
8. Differential pressure switch – with a range of up to 500 Pa
- 8.1. Pressure-measuring tube

An indirect gas heater section consists of the section housing and an indirect gas heater.

The basic indirect gas heater section outline, applicable to all indirect gas heater types, is shown in the figure below.

The indirect gas heater consists of a heat exchanger, a pressure gas burner, a burner (gas) train, and monitoring and safety equipment.

The stainless steel sheet heat exchanger consists of a

combustion chamber, a coil set and a collection chamber with a flue gas pipe. A flue gas condensate collection and drain pan is fitted below the heat exchanger.

The gas burner is flange-mounted to the combustion chamber opening from the outer (access) side of the section housing, while the flue pipe is routed through the section housing back wall. The declared minimum surrounding temperature for the normal operation of the gas is -15 °C.

Humidification section

The humidification section offers the ability to increase the humidity of the inlet air to a suitable temperature.

Types of humidification units:

- Humidification section with a spray humidifier

Humidification section with a spray humidifier: BLW

A spray humidifier section consists of a single-wall housing, a pool made of steel sheet 1.4301 and other components. The pool bottom surface is inclined towards the drain connection, which is located at the lowest point of the bottom.

The airflow-directing element and droplet eliminator consist of polypropylene fins (blades). For cleaning, they can be removed from the section housing.

The PVC pipe system consists of a pressure line, internal distribution piping, water spray nozzles, rinse and drain pipes, and a water supply pipe.

The inspection door is fitted with a window to allow inspection during operation.

The humidification section lighting is fitted on the outer side of the front panel.

A level switch prevents dry operation.

Option: the flanged pump can be made entirely of stainless steel.

- Humidification section with a steam humidifier
- Humidification section with a honeycomb humidifier
- High-pressure humidifier

Water treatment

Higher salt concentrations in spray water, caused by water evaporation (air humidification), increase the risk of excessive precipitation in the water part of the humidification section and in the pipes.

A few water treatment (softening) methods:

- Polyphosphate addition
- Ion exchange

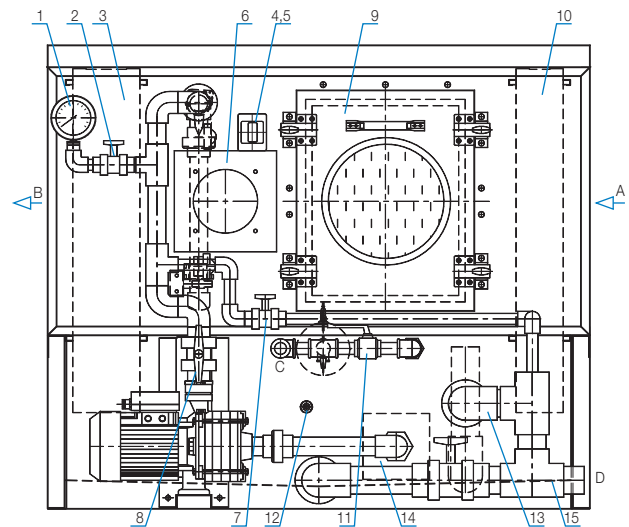

1. Manometer in the pressure line
2. Stop valve before the manometer
3. Droplet eliminator
4. Electric switch
5. Power distribution box
6. Light
7. Manual 2-way valve for rinsing
8. 2-way valve in the pressure line
9. Door with an inspection window
10. Airflow directing rectifier
11. Quick water fill valve
12. Level switch – minimum water level maintenance
13. Overflow pipe with a trap for $\Delta p \leq 1000$ pa
14. Intake strainer
15. Drain pipe

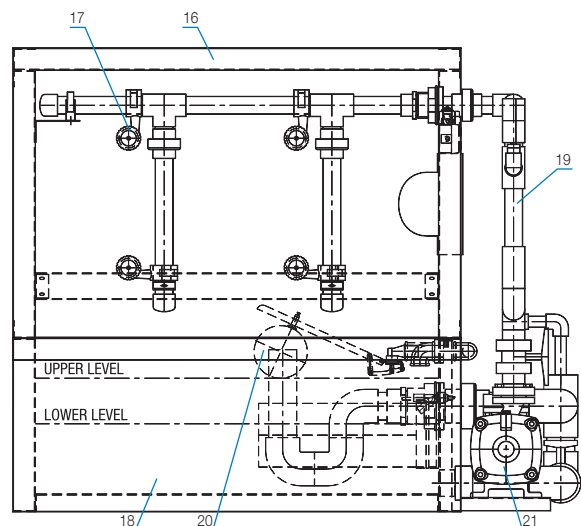

16. Housing
 17. Pressure nozzle
 18. Container
 19. Pressure distribution piping
 20. Ballcock – maximum water level maintenance
 21. Pump
- A Dry air intake
 B Humidified air outlet
 C Fresh water supply connection
 D Container water drain connection

- Decarbonisation
- Rinsing
- Occasional limescale removal

The water-spraying process in the humidifier has an additional air-cleansing function; which means that dust particles also collect in the water container.

The quantity of the rinsing water should be similar to that of the supply water for humidification, and can be determined with the following equation:

Quantity of rinsing water:

$$QVS = VZ \cdot (x2 - x1)$$

Q_{vs} amount of water used for humidification (kg/h),

V_z amount of air humidified (kg/h),

$(x2 - x1)$ change in the absolute humidity of air due to humidification (g/kg).

Humidification section with a steam humidifier: BD

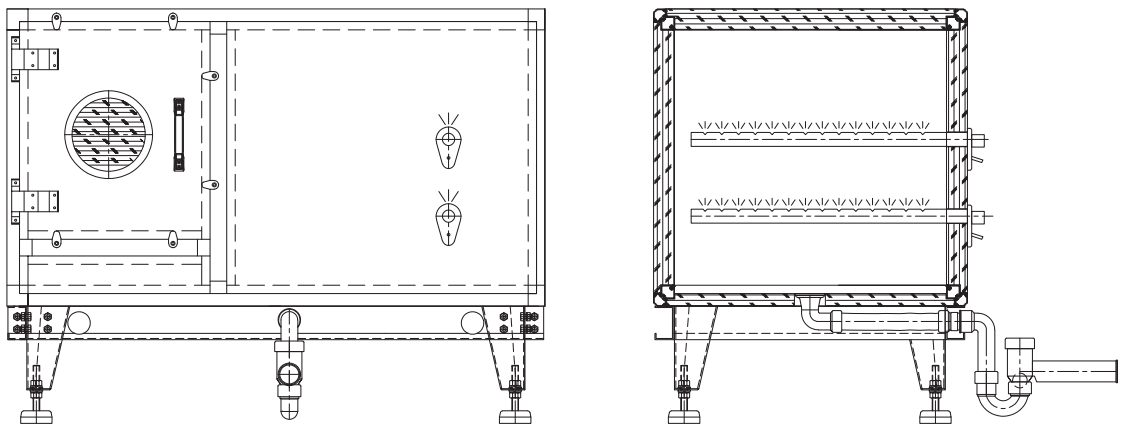

The steam humidifier section consists of a section housing, a steam humidifier, a condensate collection and drain pan, a positive or negative pressure condensate drain siphon, an access door with an inspection window, and internal lighting.

The steam humidifier consists of a steam distributor, which can be connected directly to the negative pressure steam system through a valve, or to its own steam generator. The

steam distributor connection to the generator or the negative pressure steam system is established on the outer side of the housing back wall.

The steam distributor is selected according to the humidification requirements and air handling unit size. Its installation according to the manufacturer's instructions ensures a relative air humidity rate at the end of the humidification section below 90%.

Humidification section with a honeycomb humidifier: BWA

The honeycomb humidifier section consists of a section housing, a honeycomb humidifier, and a negative or positive pressure condensate drain siphon. It is also fitted with a double-wall inspection window, and internal lighting.

Two honeycomb humidifier models are available:

- Honeycomb humidifier with circulating water
- Honeycomb humidifier with direct water

Humidification efficiency at 2 m/s airflow velocity:

- 65% (cartridge thickness 100 mm)

- 85% (cartridge thickness 200 mm)
- 95% (cartridge thickness 300 mm)

A droplet eliminator is required for every section where airflow velocity exceeds 3.5 m/s.

A solenoid valve allows water supply control for each cartridge independently (max. 5 cartridges).

Multi-step control is available with both the circulating and direct water honeycomb humidifier model.

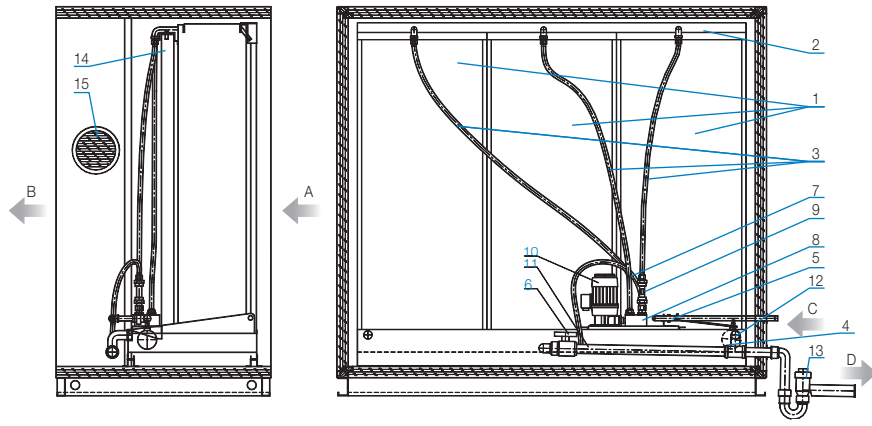

Honeycomb humidifier with circulating water

- A Intake air
- B Humidified air
- C Water supply
- D Waste water drain
- 1. Humidification cartridge
- 2. Water distribution head
- 3. Water distribution pipes
- 4. Float
- 5. Float-connected valve
- 6. Valve for tank rinsing
- 7. Rinse pipe
- 8. Water distributor
- 9. Flush control valve
- 10. Pump
- 11. Overflow pipe
- 12. Tank drain and rinse pipe
- 13. Negative pressure drain trap
- 14. Droplet eliminator
- 15. Inspection window

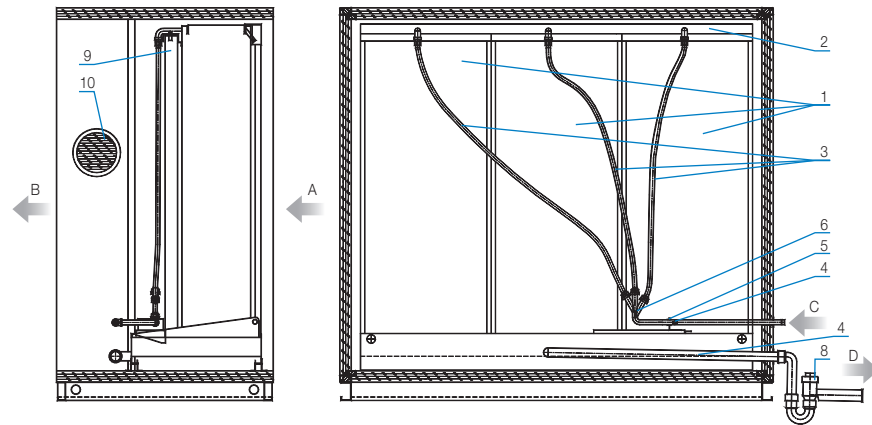

Honeycomb humidifier with direct water

- A Supply air
- B Humidified air
- C Water supply
- D Exhaust water drain
- 1. Humidification cartridge
- 2. Water distribution head
- 3. Water distribution pipes
- 4. Water distributor
- 5. Negative pressure drain trap siphon
- 6. Water distributor
- 7. Tank drain and flush pipe
- 8. Constant water flow rate control valve
- 9. Droplet eliminator
- 10. Inspection window

Water consumption

Water circulation system:

Total water consumption equals the sum of absorbed (E) and rinsed (O) water.

Flushing the humidification section water tank is necessary to maintain an appropriate level of mineral and salt concentration in the water.

Rinse factor:

With established water quality, the rinse factor (f_o) can be determined from the water quality diagram (see below). If the rinse factor (f_o value) is more than 2, we recommend using a direct water system or improving the water quality.

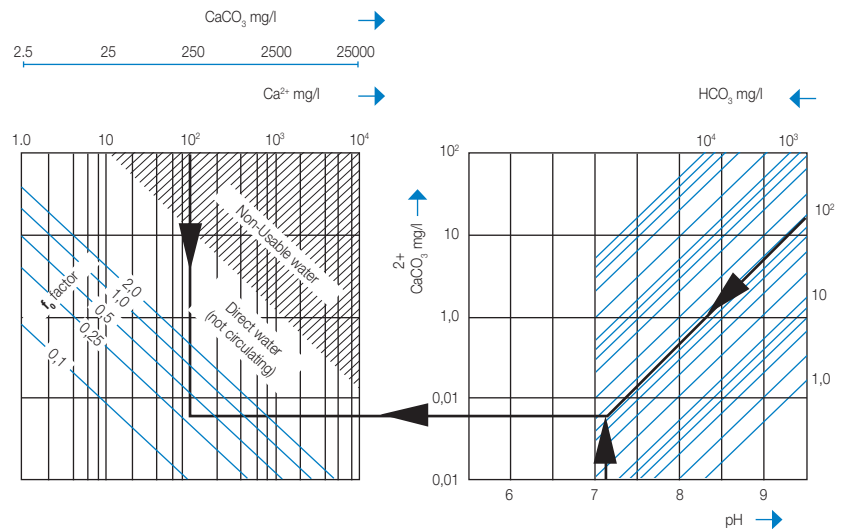

Calculation example:

$V = 2,8 \text{ m}^3/\text{s}$

$\text{pH} = 7,1$

Calcium concentration

$(\text{Ca}^{2+}) = 100 \text{ mg/l (100 ppm)}$

Bicarbonate concentration

$(\text{HCO}_3) = 100 \text{ mg/l (100 ppm)}$

Intake air humidity (x_1) = 2 g/kg

Outlet air humidity (x_2) = 9 g/kg

From water quality diagram (f_o) = 0,3

$E = (2,8 \times 60 \times 1,2 \times (9 - 2)) / 1000 =$

$E = 1,41 \text{ l/min}$

$O = 0,3 \times 1,41 = 0,42 \text{ l/min}$

$S = 1,41 + 0,42 = 1,83 \text{ l/min}$

Total water consumption:

$E = (V \times 60 \times 1,2 \times (X2 - X1)) / 1000$

$O = fO \times E$

$S = E + O$

E Absorbed water quantity (l/min)

O Rinsed water quantity (l/min)

S Total water consumption (l/min)

V Volume air flow rate (m³/h)

1,2 Standard air density (kg/m³)

X2 Intake air humidity (g/kg)

X1 Outlet air humidity (g/kg)

fO Rinse factor

60 Conversion from (m³/s) to (m³/min)

1000 Conversion from (g/min) to (l/min)

Installation

At the humidified air outlet, a 300–600 mm wide space should be provided. Upon installation, all fissures towards the housing must be sealed.

It is required that the air be filtered with ISO coarse filters before entering into the humidifier. If it contains organic particles, finer filters can be required.

We recommend the use of class ePM2.5 >50% filters according to ISO 16890 for easier maintenance and better quality.

Water supply with a circulating water humidifier:

Water supply connection:

- Stop valve*
- 500 µm water filter (if water contains coarse particles)*

The microbiological parameters of the supplied water must correspond to drinking water quality standards and regulations in force.

Water supply with direct water humidifier:

Water supply connection:

- Stop valve*
- 500 µm water filter (if water contains coarse particles)*
- Solenoid valve
- Constant flow rate control valve

The microbiological parameters of the supplied water must correspond to drinking water quality standards and regulations in force.

Water outlet:

Due to the negative pressure in the humidification section, an adequate negative pressure trap is necessary to allow rinsing.

Control:

Applicable to circulating and direct water humidifiers:

- One-step control*
- Two-step control*
- 3-, 4- or max. 5-step control available upon request*
- An external solenoid valve is not supplied with the humidifier

With multi-step control, the section has one internal solenoid valve less than the number of regulation steps.

* not part of humidifier standard equipment

Technical specifications

Supply water requirements

	Circulating water	Direct water
Minimum pressure	500 kPa	150 kPa
Maximum pressure	1000 kPa	1000 kPa
Temperature	0°C – 40°C	0°C – 40°C

Electromagnetic valve

Voltage (V)	Frequency (Hz)	Power (W)	Current (A)
230	50 – 60	6 – 12	0,10 – 0,21

Pump motor

Pump size*	Voltage (V)±10 %	Frequency (Hz)	Power (W)	Current (A)
1	230/400	50	50	0,26/0,15
2	230/400	50	125	0,38/0,22
3	230/400	50	170	0,75/0,43
4	230/400	50	270	1,10/0,63

Pump motor protection: IP 54, EN 60034
 Pump motor insulation: class F

High-pressure humidifier

A high-pressure humidifier is used for adiabatic humidification of inlet air; therefore a spray-nozzle system is installed in the inlet section of the air handling unit.

Main characteristics:

- The system is hygienic and harmless to health, certified according to VDI 6022 and appropriate for hospital use.
- All components are made of stainless steel or plastics and are corrosion resistant.

Main components:

1. A high-pressure pump aggregate featuring a pump motor with an adjustable number of revolutions controlled by a frequency controller and pressure sensor. The aggregate uses water prepared to correspond to different quality levels. The maximum allowed water

hardness is 4 odH (German grades). It can use softened or demineralised water.

Protection elements on the pump:

- Pressure switch
- Temperature controller
- Pressure valve

2. A nozzle system, consisting of:

- Pressure nozzles
- A stainless steel pipe system
- High-pressure flexible hoses to connect the pump aggregate and the nozzle system, with corresponding fittings.

3. A drop eliminator, installed at the end of the functional unit, to eliminate aerosols from the airflow. It prevents

corrosion of the elements installed downstream of this functional unit.

4. Electrical control cabinet with drive, protection and control functions. All functions are operated by a preset controller that provides complete humidification functionality.

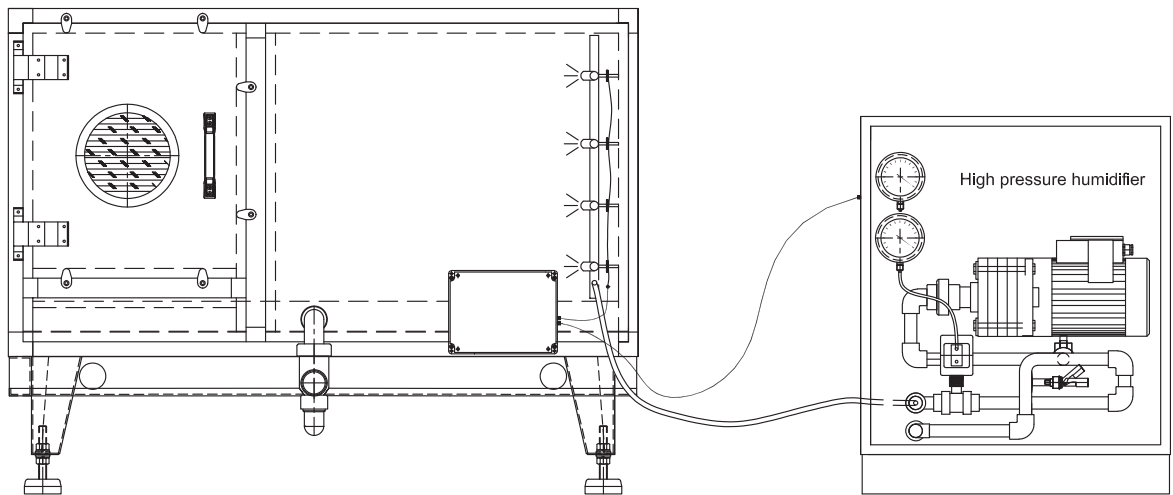

Cooling section

The cooling section cools the inlet air in the summer. It is designed based on the inlet parameters and flow rate.

Types of cooling units:

- Cooling section with a water cooler
- Cooling section with a water cooler with droplet eliminator
- Cooling section with direct expansion (DX)

Cooling unit with a water cooler: KW

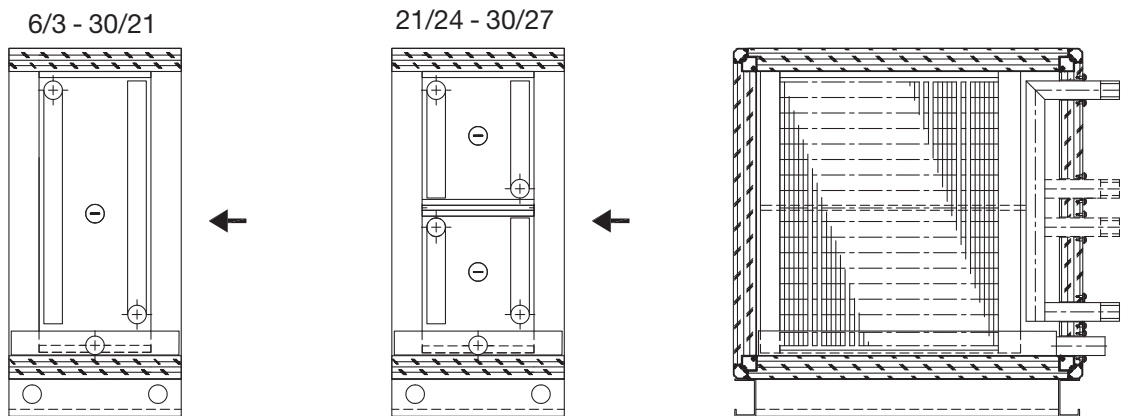

This water cooler section consists of a section housing, a water cooler, a droplet eliminator, a condensate collection pan, and a negative or positive pressure siphon for draining the condensate from the pan.

Every water cooler is tested for tightness in a water bath at a test pressure corresponding to the operating pressure. The water heater is mounted in the housing with guides allowing its removal in case of defect or damage.

Cooling section with a water cooler with droplet eliminator: KW-TA

The droplet eliminator consists of a galvanized steel sheet frame with polypropylene blades to capture water droplets. It is mounted in the section housing above the condensate collection pan and can be pulled out of the housing on guides. For complete droplet elimination, the airflow velocity should not exceed 3.5 m/s.

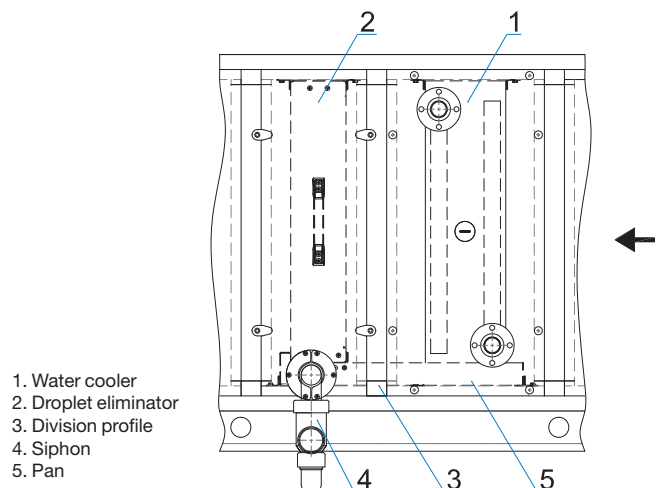

Horizontal design

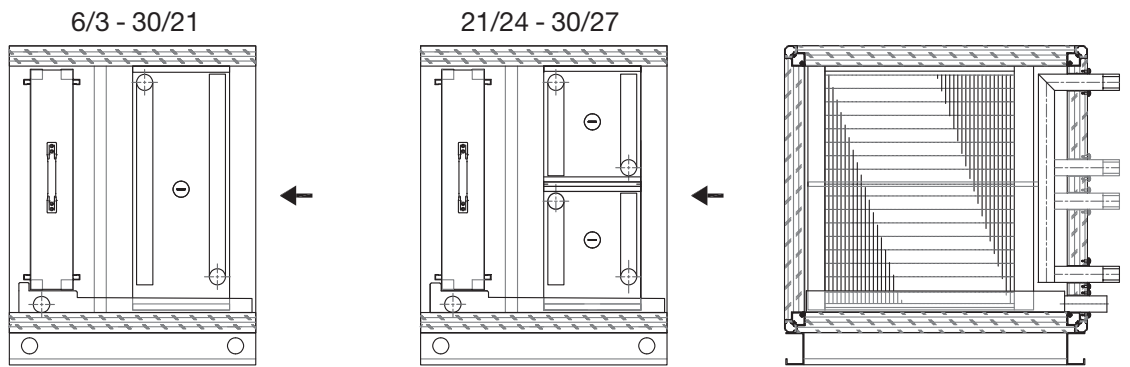

Vertical design

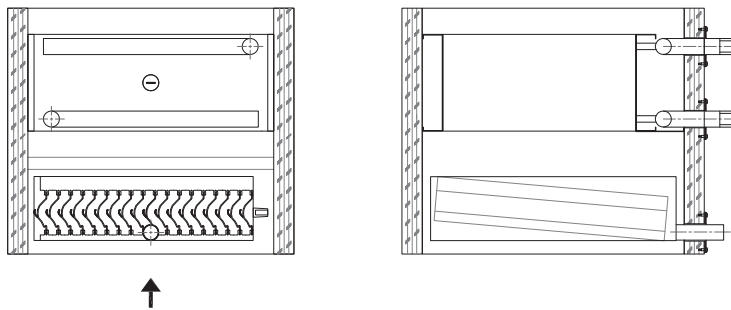

Cooling section with direct expansion (DX): KD

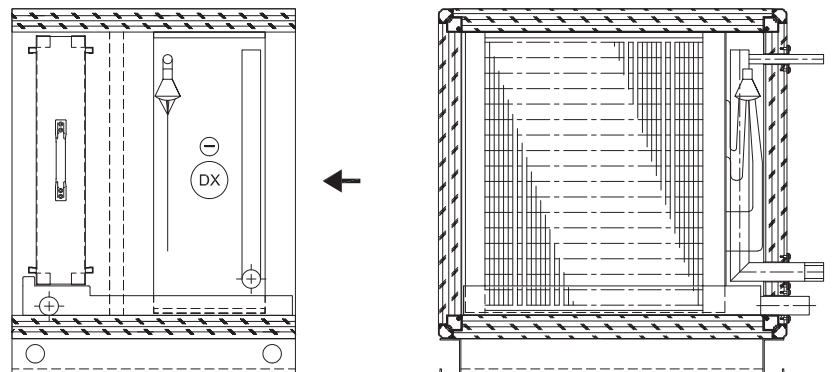

A cooling section with direct expansion with a droplet eliminator: KT-DA

The DX cooler cools the air using Freon-based cooling agents (R410a and R407c). If required, a DX cooler can be

divided into two or more cooling circuits.

A direct evaporator is mounted in the housing with guides allowing its removal in case of defect or damage.

Siphon

A siphon is a plastic pipe which enables condensate to drain in case of negative pressure in the air handling unit or an individual section, and prevents air leakage through the drain pipe in case of positive pressure in the unit or an individual section.

For siphon dimensioning, see separate Installation Manual.

Positive pressure siphon

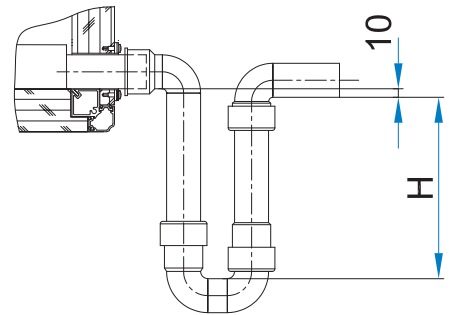

Negative pressure siphon with a ball

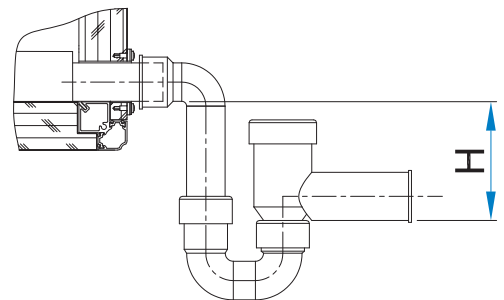

Compressor section: KO

The compressor section consists of a section housing, one or more compressors and their respective cooling circuit components, a condensate collection pan, and a negative or positive pressure siphon.

It may be designed as an independent section or as part of another section, such as a mixing section, plate recuperator section, etc.

This section always contains an access door with an inspection window and an internal light as an option.

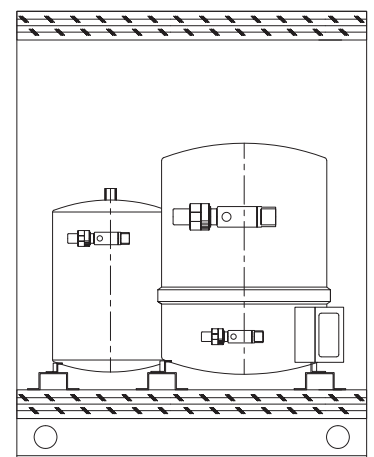

Filter section

The filter section maintains the quality of the inlet air. Based on the desired air quality and level of filtration, different filters are installed: panel, bag, metal, high-efficiency, or activated carbon filter sections.)

Panel filter section: FK

A panel filter consists of a galvanized sheet steel frame with a width of 100 mm and an inserted zigzag filter medium made of synthetic fibres. Filter mediums are resistant to temperatures up to 70 °C, with the exact temperature range stated by manufacturers.

For the initial and recommended final pressure drop values, see the technical data sheet generated in the selection software for each air handling unit.

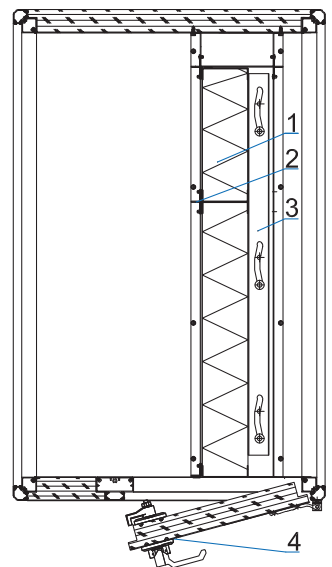
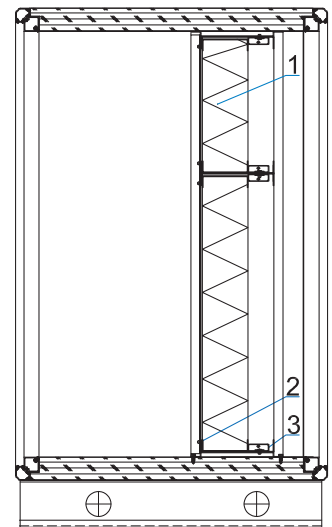

- 1. Panel filter
- 2. Guide
- 3. Mechanical lock
- 4. Door

Bag filter section: FT (filter access from the dirty side)

The filter medium is clamped to the bag filter frame using spring clamps.

Bag filters are delivered in two lengths (360 or 600 mm) and can be made of two different types of material: fibre-glass or synthetic fibres, with temperature ratings up to ≈ 70°C. The manufacturers determine the exact temperature resistance range.

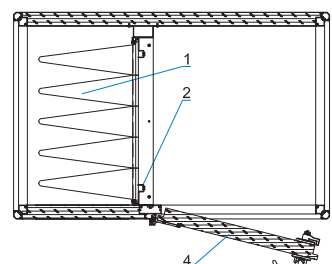
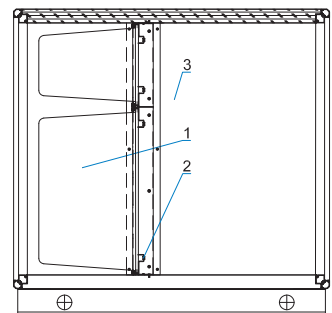

- 1. Bag filter
- 2. Bag filter frame with spring clamps
- 3. Space for bag filter removal
- 4. Door

Bag filter section: FTT
(filter access from the clean side)

This filter section has a door on the access side, to install or remove bag filters into or from the frame.

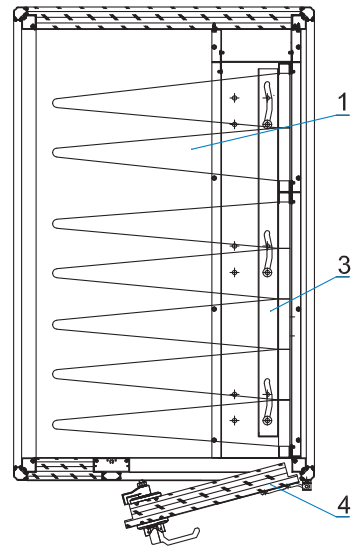
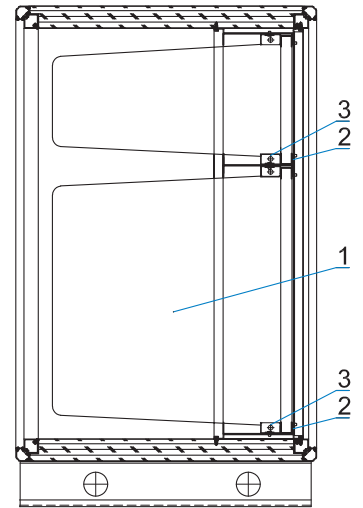

- 1. Bag filter
- 2. Guide
- 3. Mechanical lock
- 4. Door

Metal filter section: FM

A metal filter consists of a structural frame made out of galvanized steel sheet with an inserted Coarse 30% or Coarse 40% class filter medium. The metal filter material may be galvanized steel, stainless steel or aluminium. This filter type is only suitable for very coarse air filtration.

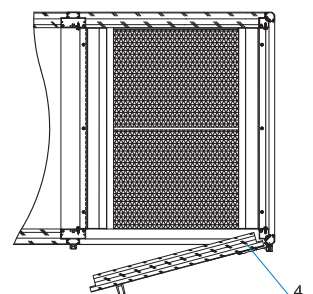
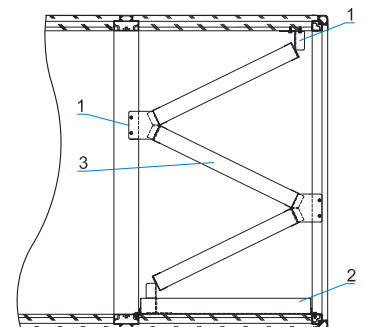

- 1. Structural frame
- 2. Pan
- 3. Metal filter
- 4. Door

Activated carbon filter section: FAK

An activated carbon filter consists of a galvanized sheet steel base plate and cylindrical activated carbon cartridges.

The installation of the activated carbon filter base plate in the filter frame is air-tight.

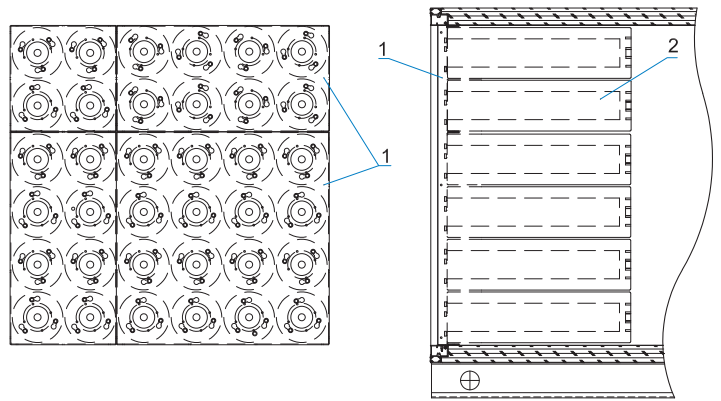

- 1. Base plate
- 2. Filter plate

High-efficiency filter section: FA

A high-efficiency filter consists of a structural frame and an H10 to U17 filtration class filter medium.

A high-efficiency filter is mounted on the structural filter frame with a removable screw joint. The filter housing is pressed against the sealing strip glued to the structural filter frame.

- Filtration class H10 – U17 according to EN 1822.

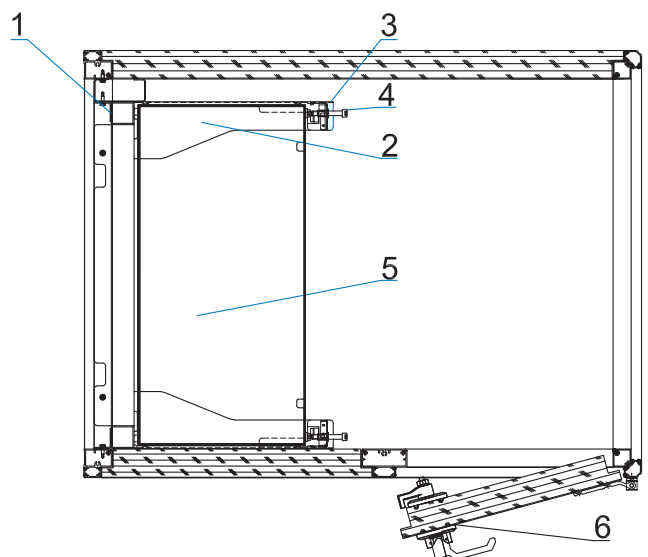
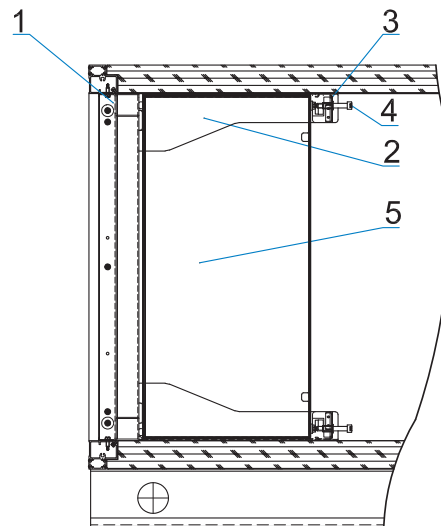

- 1. Structural filter frame
- 2. Structural profile
- 3. Sealing profile
- 4. Screw
- 5. High-efficiency filter
- 6. Door

Sound attenuation section: S

An attenuator consists of an outer frame made out of galvanized stainless sheet steel with mineral wool filling. Sound attenuators for hygienic air handling units have an additional protection of a special hydrophobic foil, certified according to VDI6022-1.

Sound attenuators for swimming pool air handling units are protected with polyethylene foil.

Each splitter can be removed from the housing.

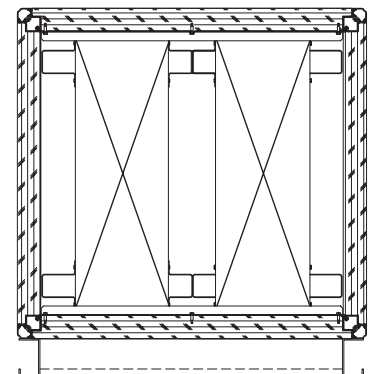
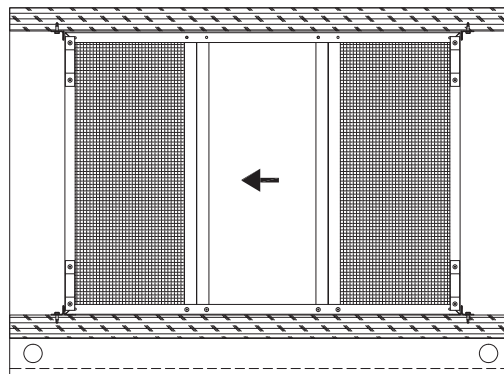

Heat recovery section

The recuperation section is designed for heating in winter and cooling in summer. The efficiency of the system with a recuperation section is from 60 to 90%, resulting in significant energy savings.

Types of recuperation units:

- Recuperation section with a run-around coil
- Recuperation section with a cross-flow plate heat exchanger
- Recuperation section with a double plate cross-flow heat exchanger
- Recuperation section with a counter-flow heat exchanger
- Regeneration section with a rotary heat exchanger
- Heat pump

Recuperation section with a run-around coil

This recuperator section consists of a section housing and a recuperator which includes an outlet air water cooler, an intake air water heater, and a pipe system.

The run-around recuperator consists of two coil heat exchangers connected by a pipe system with a circulation pump. One of the heat exchangers functions as a cooler in the exhaust airflow part, and the other as a heater in the supply airflow part.

The pipe connection and additional elements, such as pumps, valves or expansion vessels, are provided by the installer.

Recuperation section with a heating coil: RKE

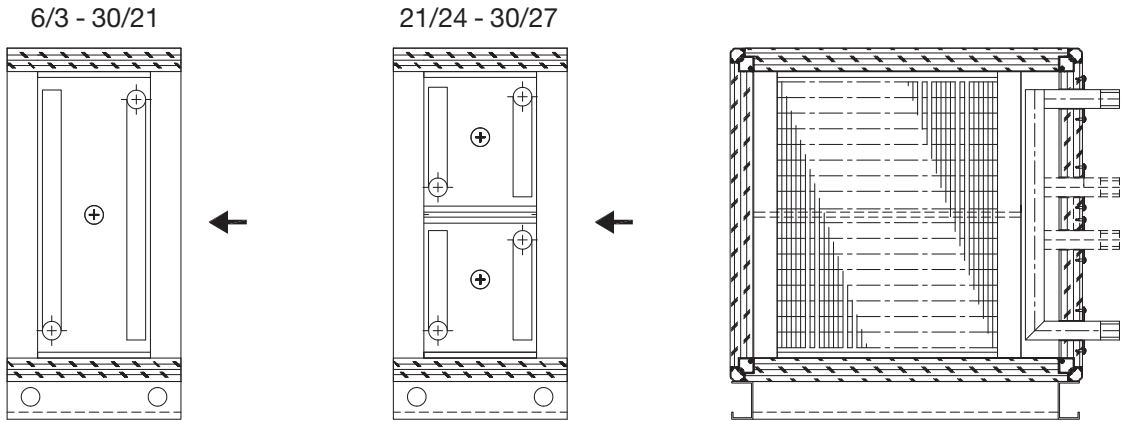

Pipe connection dimensions depend on individual air handling unit sizes and other input parameters.

Recuperation section with a cooling coil: RKK

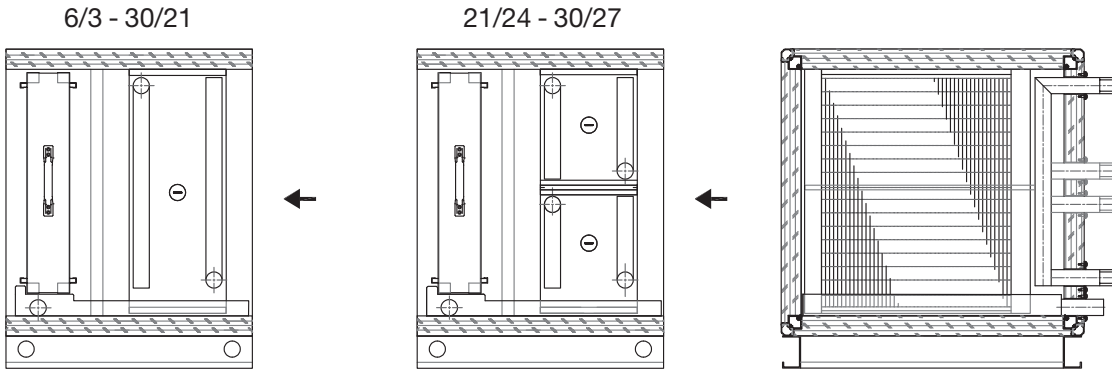

Recuperation section with a cross-flow plate heat exchanger – diagonal design, with a droplet eliminator and a panel filter: RPD-TA-FK

- 1. Plate recuperator
- 2. Bypass damper
- 3. Droplet eliminator
- 4. Filter
- 5. Actuator
- 6. Condensate collection and drain pan
- 7. Bypass
- 8. Siphon

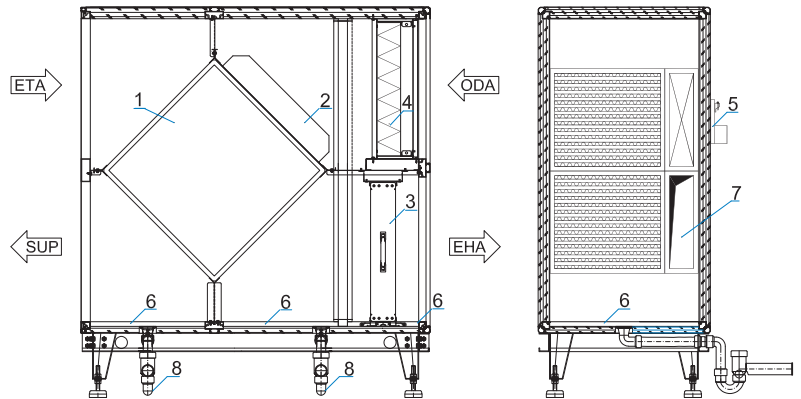

This cross-flow plate recuperator section consists of a section housing, a plate recuperator, a bypass damper, a droplet eliminator, and a panel filter at outside/fresh air inlet.

The recuperator consists of flat aluminium plates providing the structure with stability. The supply and exhaust air pass through the recuperator in a cross-flow. Air leakage between the exhaust and supply air flows can be up to 1% of the nominal air flow rate with a pressure differential of 1000 Pa.

For capacity regulation and anti-freeze protection, the recuperator is fitted with an air bypass installed within the air handling unit.

The recuperator also provides heating power control during seasonal transitions, summer cooling power control, and antifrost protection. It achieves this by opening the bypass and thus reducing the fresh air flow rate through the recuperator.

Recuperation section with a double plate heat exchanger RPBD

This heat exchanger type is recommended if higher heat recuperation efficiency is requested. A standard package includes by-pass dampers for heat capacity control during seasonal transitions (free cooling) and frost protection in winter.

- 1. Double plate exchanger
- 2. By-pass damper
- 3. Damper
- 4. Inclined drain pan
- 5. Drain pan
- 6. Siphon

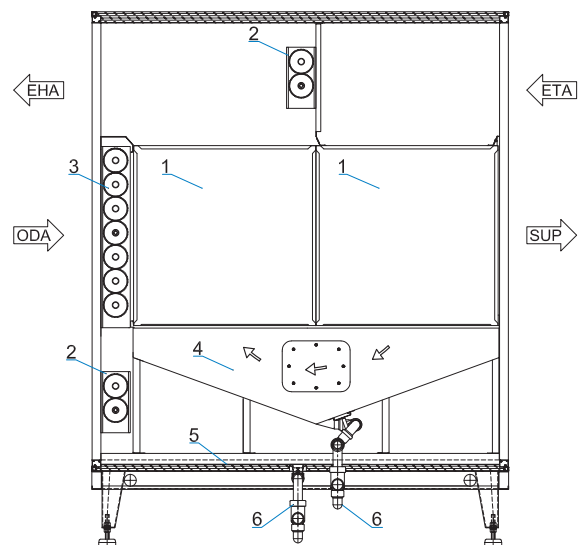

Recuperation section with a counter-flow heat exchanger RPDC

Counter-flow heat exchangers have higher efficiencies in comparison with cross-flow heat exchangers.

- Recovery of sensible heat from the outlet to the inlet (fresh) air flow, recovery efficiency over 90%
- Airtightness between inlet and outlet air flow

It consists of:

- An aluminium filler from shaped flat plates which can be epoxy-coated upon request.
- Galvanized steel sheet side panels which can be epoxy-coated upon request, as well as additional corner connection profiles.

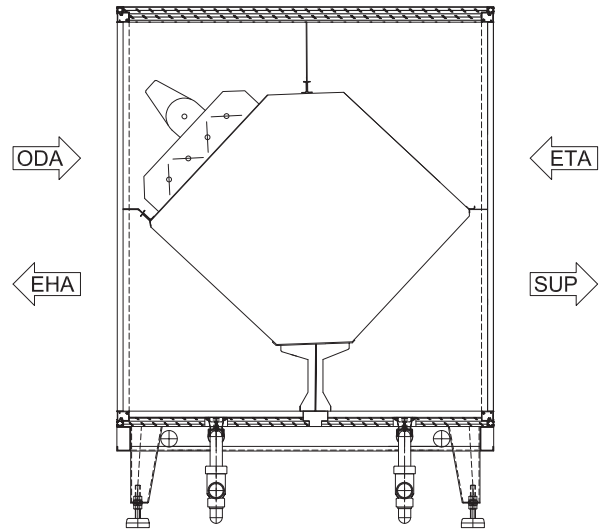

Recuperation section with a rotary heat exchanger: RRG

This recuperation section consists of a section housing and a rotary regenerative wheel.

The rotary wheel is installed into the section housing, from which it can be removed in one piece, or, in case of large sections, in segments.

Two stage design

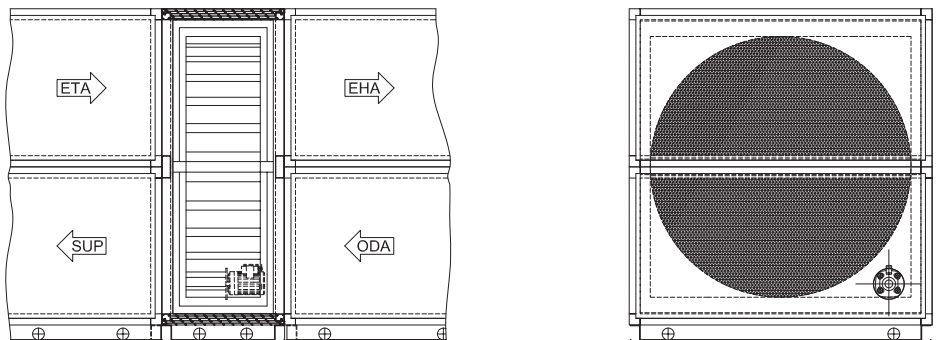

Parallel design

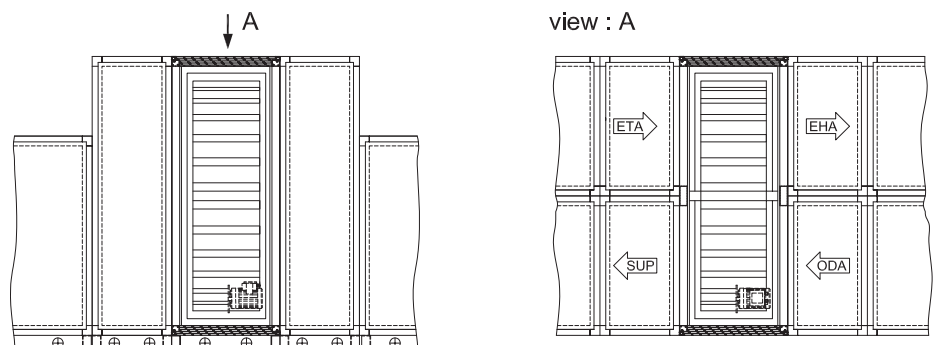

Heat pump

The heat pump or cooling system consists of the basic elements that are described in individual section chapters (evaporator, condenser, compressor), as well as elements for the regulation, control and protection of the system. Depending on the installation of an evaporator or a condenser on the supply side of the air handling unit, the system can be used for cooling, heating or even for cooling and heating, depending on the season.

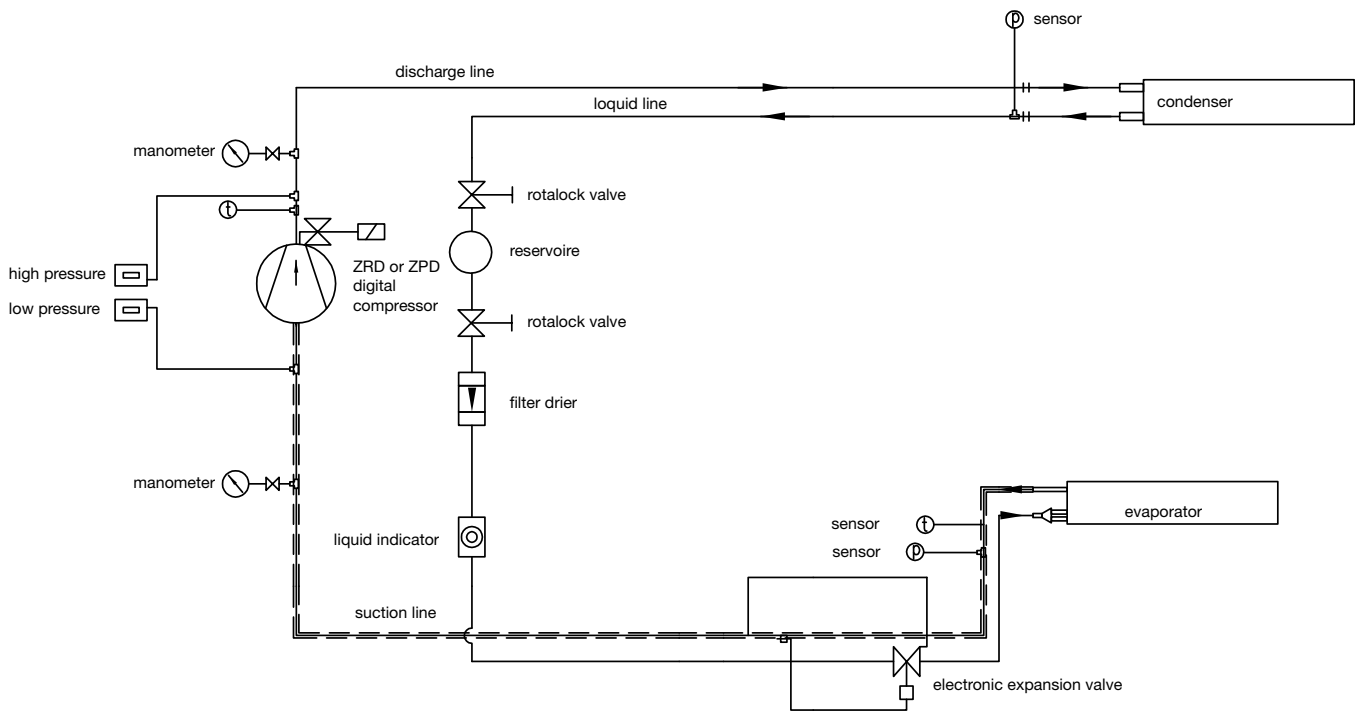

Controls

Control system

Air handling units can be supplied with a complete control system. Our services include:

- Technical support to designers
- Remote control
- Design and construction of electric Control cabinets
- Wiring
- Functional start-up of air handling units in the factory
- Optional: final start-up on site as a separate service on request

Automation

To ensure the optimum operation of HVAC systems, we use control equipment with standard software compatible with cloud solutions. As a result, we can offer tailored solutions for even the most complex and comprehensive HVAC systems and issue unique functional warranties for individual projects.

As peripheral equipment, we install elements by leading manufacturers, e.g. Belimo, Danfoss, Carel, Regin, etc.

Remote operation

An integrated TCP/IP server, remote displays and touch-screens allow simple and user-friendly operation of our air handling units and comprehensive HVAC systems and offer an overview of system functions in an internet browser. On request, we can also include system visualization.

Electric control cabinets

We design and manufacture in-house electric control cabinets to provide complete adaptability to the requirements of the customer or the project.

The cabinets can be installed internally or externally and contain all power and control elements.

During production, each electric control cabinet undergoes a power test and functional test.

Wiring in production or on site

The wiring of the peripheral equipment is carried out in the factory according to the individual electrical wiring diagram. On request, the wiring can also be carried out on the



site of the final installation of the air handling unit.

In case of split delivery of air handling unit sections, the connectors are pre-prepared in the factory for easier on-site assembly. All connectors and cables are marked accordingly.

The heating and cooling circuit pipe installation with valves, pumps, manometers, etc. can also be fitted in the factory, to simplify the on-site installation.

Functional start-up

The functional start-up includes setting all project parameters and testing all air handling unit functions according to the requirements of the project.

Upon completing the start-up, the customer receives complete documentation describing system operation and all warranty statements.

For all air handling units where Lindab supplies the control system we issue a functional warranty.

On request, the final start-up can also be carried out on site.

Continuous management of cooling power

Compressors with linear driven capacity:

- Digital scroll compressors
- BLDC compressors

Advantages:

- Higher load possibility
- Precise temperature regulation (+/-0.5°C)
- Precise humidity regulation
- Higher level of system stability
- Decreased power consumption

Digital scroll compressors

- Copeland compressors
- Emersson controller
- Capacity regulation 10–100%
- Integrated regulation of the DX electronic expansion valve

Integration in a building management system (BMS)

The software provides:

- A user-friendly graphical overview of the entire system
- Event and alarm database management
- Overview of alarms
- Overview of trends
- Overview of events
- Alarm and event management
- Calendar and scheduled operation
- Report editor

- Access right management
- Modem or internet communication

The software integrates all communications protocols, commonly used for HVAC, such as:

- Modbus
- BacNet
- Lon Works
- Exoline



Good Thinking

At Lindab we simplify construction for our customers. We do that by designing easy-to-use products and solutions, as well as offering efficient availability and logistics. We are also working on ways to reduce our impact on our environment and climate. We do that by developing methods to produce our solutions using a minimum of energy and natural resources, and by reducing negative effects on the environment. We use steel in our products. It's one of few materials that can be recycled an infinite number of times without losing any of its properties. That means less carbon emissions in nature and less energy wasted.

We simplify construction