

JCE HOODS

Product brochure

Jeven
Top ventilation for top chefs

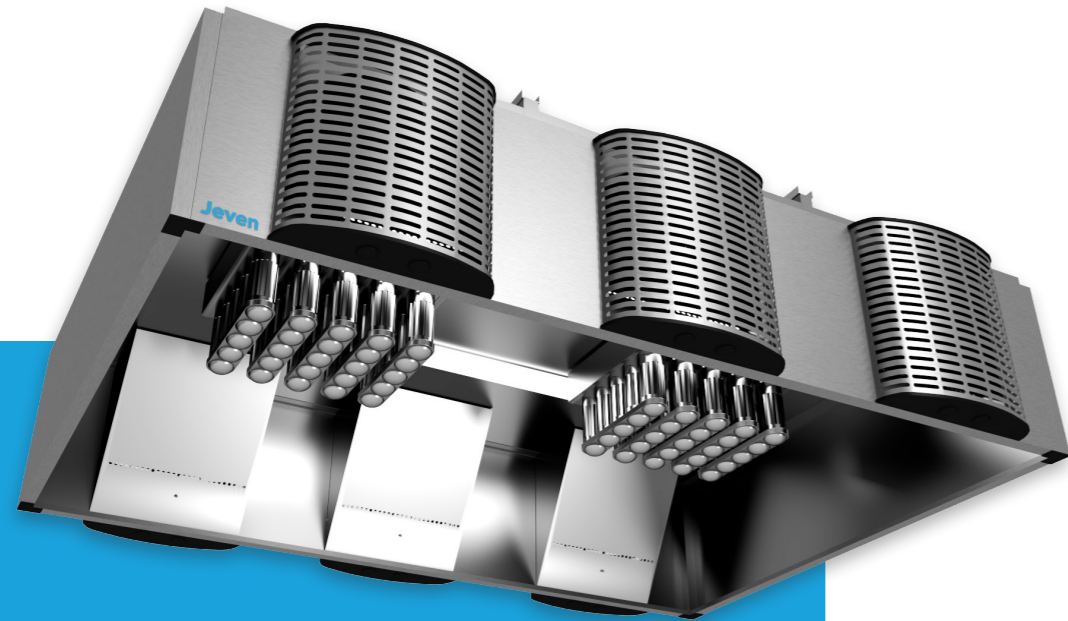
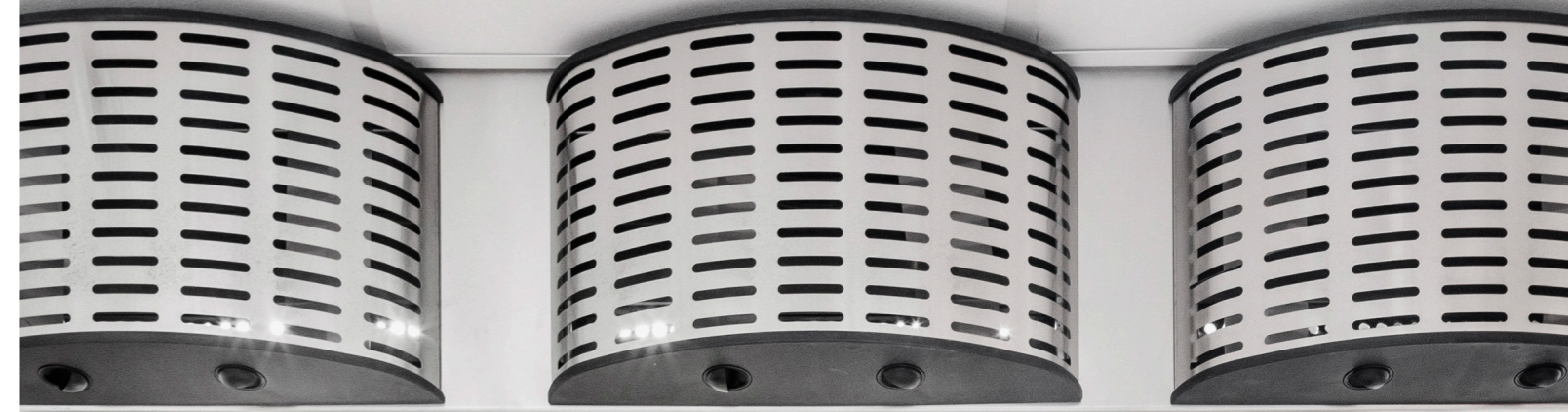

TABLE OF CONTENTS

FUNCTIONING PRINCIPLE	04
PRODUCT STRUCTURE	05
JCE FILTER UNIT	06
EXHAUST AIR	07
SUPPLY AIR	09
LIGHTS	11
DIMENSIONS.....	12
POSITIONING, PRODUCT CODE	13

All rights reserved



JCE HOODS

Traditional hoods, equipped with JCE cyclone filters, are a sure choice for distribution, heating and institutional kitchens, such as schools, kindergartens and service homes.

Supply air integrated to the hood offers draught-free, healthy and efficient indoor climate for the professionals working in commercial kitchens. Supply air columns allow individual adjustment of air patterns and air flows.

Modularity makes it easy to vary both the number and positioning of the supply air columns and the shapes of the hoods.

Both the columns and the grease filters are easy to remove and wash in a dishwasher.



Pizzarium, Iso Omena

FUNCTIONING PRINCIPLE

- 1 Dirty air rises due to temperature differences against the ceiling of the hood.
- 2 Direction air prevents leakage and directs steam and impurities towards JCE filter unit.
- 3 Grease particles and dirt are removed in the cyclonic JCE grease filters.
- 4 Clean air is exhausted into the ducts.
- 5 Fresh and draught-free supply air is brought into the kitchen through the supply air columns placed on the outside walls of the supply air hood. This results in very effective ventilation in the kitchen.

SUPPLY AIR HOOD JSI

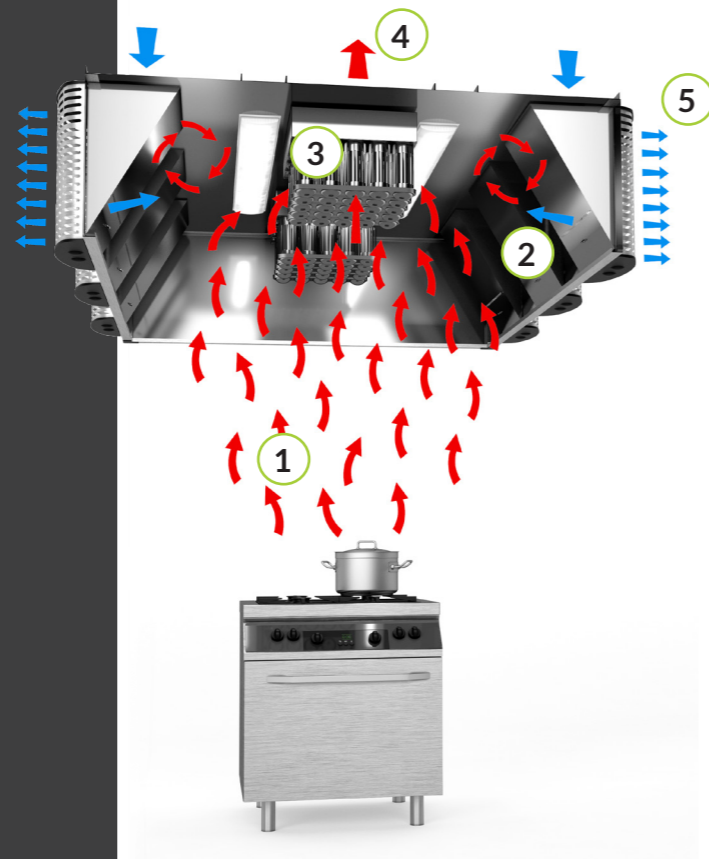

HOOD JLI

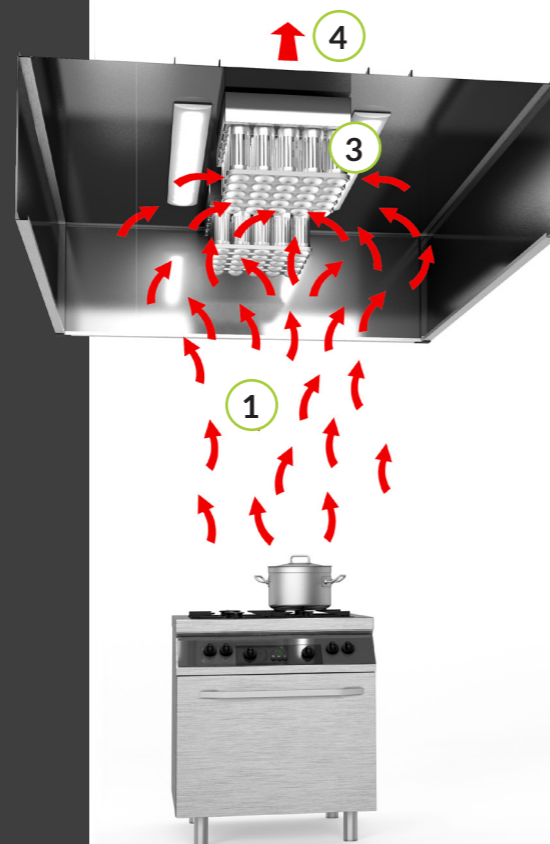

PRODUCT STRUCTURE

JCE HOODS

- 1 JCE grease filters and measurement tap for the exhaust air
- 2 Direction air unit with measurement tap for the supply air
- 3 LED lights
- 4 Exhaust air connection and damper plates
- 5 Supply air unit with removable front panel
- 6 Supply air connection and damper unit

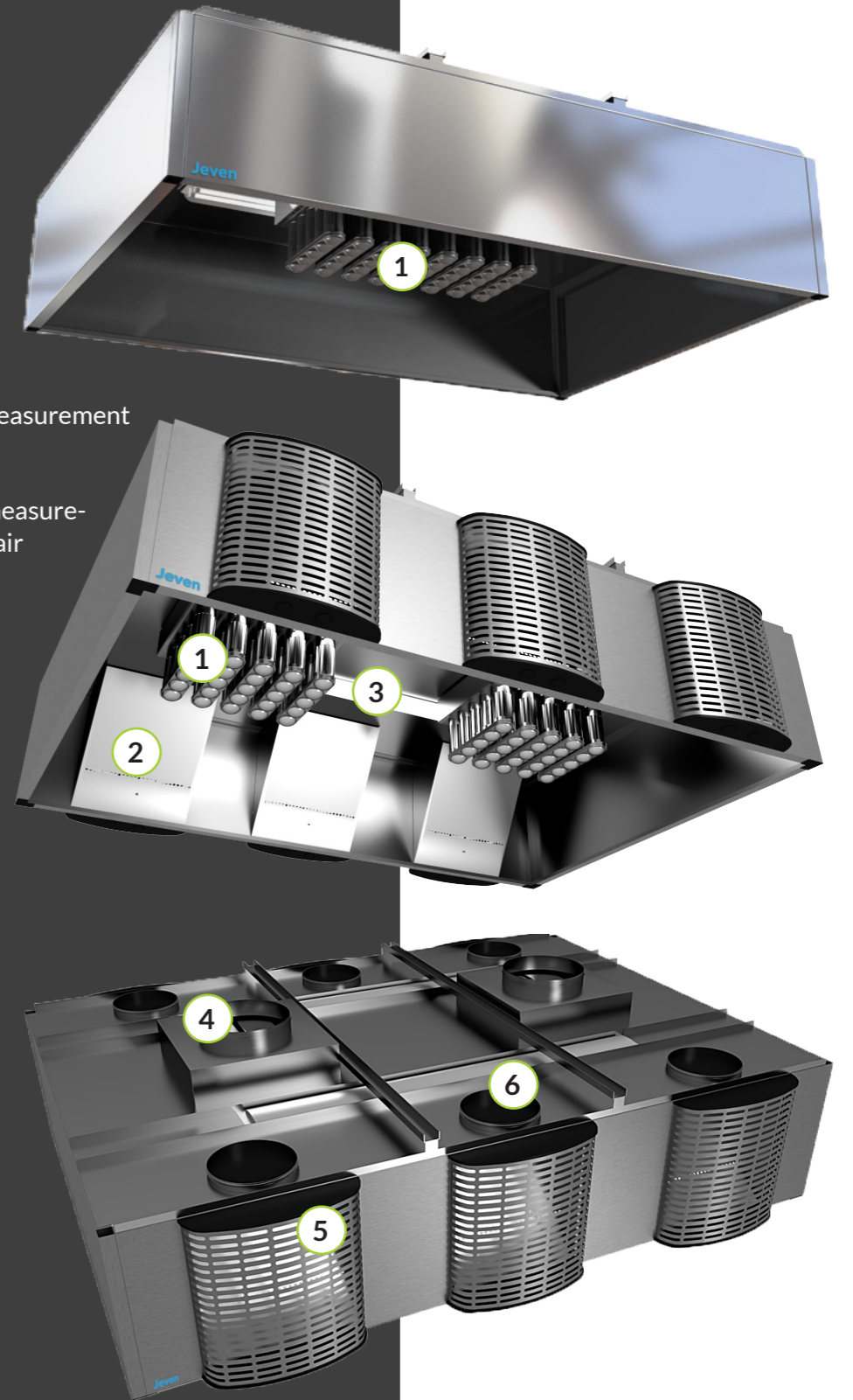

PRODUCT STRUCTURE

JCE FILTER UNIT

- 1 Separation chamber
- 2 Exhaust air connection and damper plates
- 3 JCE grease filters
- 4 Measurement tap for the exhaust air
- 5 K-factor stickers

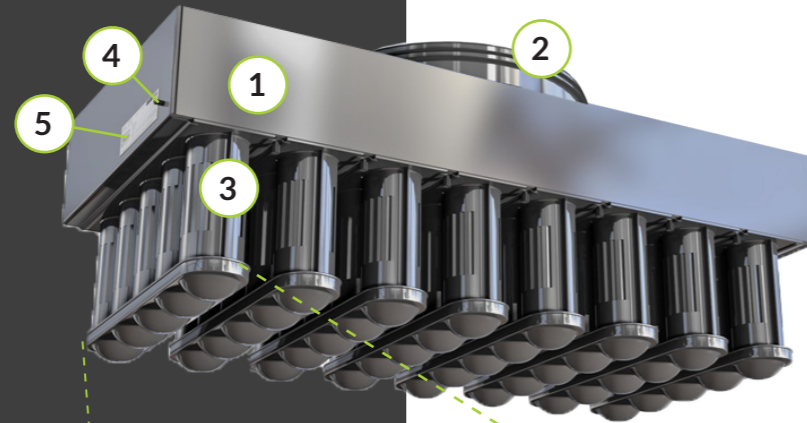

FUNCTIONING PRINCIPLE

JCE FILTER

- 1 Greasy air enters the JCE cyclonic grease filter.
- 2 As the airflow rotates in the filter, the grease separates into the filter walls thanks to centrifugal force.
- 3 Grease and dirt pour from the wall down to the grease cup.
- 4 Clean air is exhausted into the ducts.

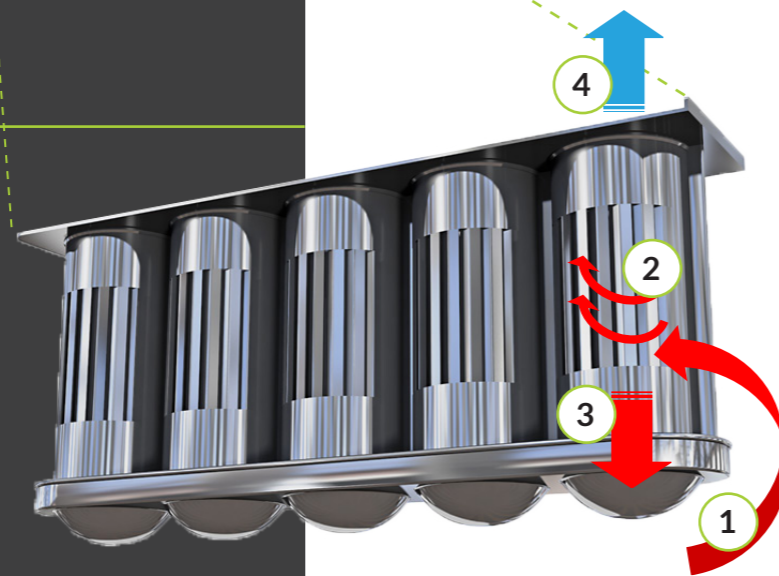

EXHAUST AIR

JCE HOODS

Grease filter extraction rate

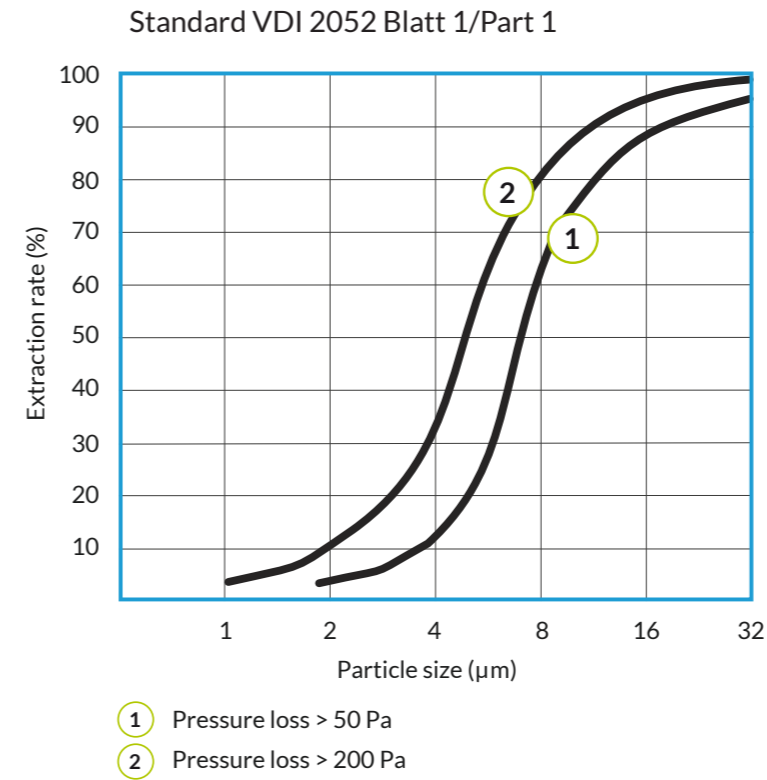

The recommended exhaust airflow rate is max. 340 l/s per 315 mm spigot, with a duct velocity of 4.4 m/s.
The nominal airflow of the filter units is 60 l/s per filter module.

Recommended exhaust flow/spigot

Spigot size \varnothing	Exhaust flow	
	l/s	m ³ /h
200	40-140	145-500
315	140-340	500-1225
400	340-530	1225-1910

By default, the canopies come with a suitable number of filter units so that the pressure level will be between 40 and 60 Pa.

Removal efficiency

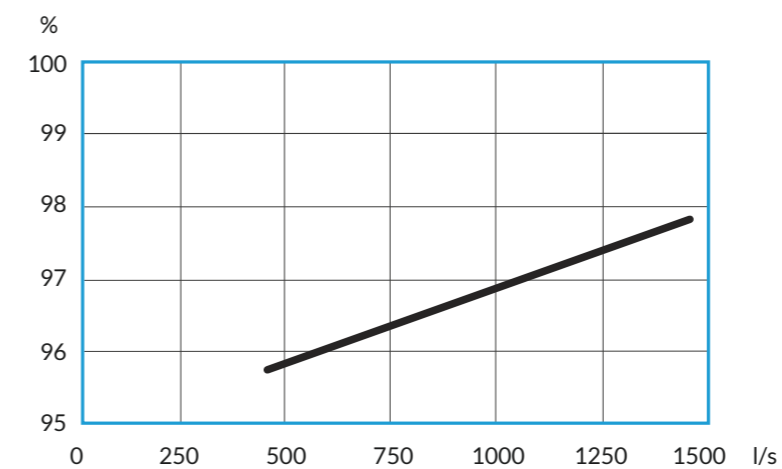

Supply air hood is equipped with direction air that effectively prevent impurities from escaping from the hood.

The 94-97 % capture rate is measured by the NORDTEST method NT / VVS 088.

EXHAUST AIR

JCE HOODS

Pressure loss and sound data

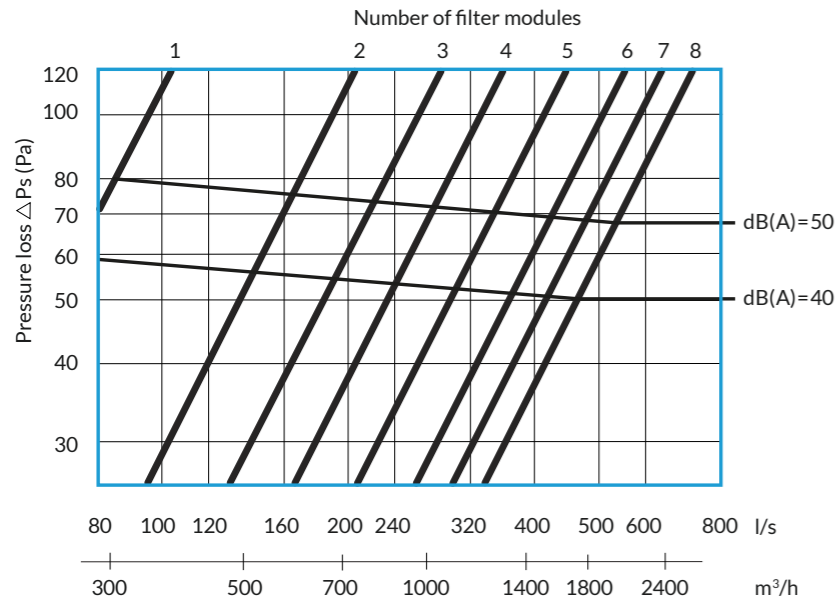

Sound Power level, L_w

Sound power level L_w in each octave band is computed by adding the corresponding factor, K_{ok} to the sound power level L_{pA} :

$$L_w = L_{pA} + K_{ok}$$

Factor, K_{ok}

Hz	125	250	500	1000	2000	4000
K_{ok}	6	5	4	-2	-9	-16
tol.	± 3	± 3	± 2	± 2	± 3	± 4

Sound attenuation

Exhaust air

JCE-2, Spigot = $\varnothing 200$ mm.
Sound attenuation, (dB)

Hz	125	250	500	1000	2000	4000
"Damper closed"	12	7	7	10	10	10
"Damper open"	11	6	6	6	6	5

Exhaust air

JCE-4, Spigot = $\varnothing 315$ mm.
Sound attenuation, (dB)

Hz	125	250	500	1000	2000	4000
"Damper closed"	3	5	4	11	10	10
"Damper open"	2	4	3	6	4	7

The average sound attenuation includes the end reflection of the connection spigot. It is recommended to use "damper open" values when calculating sound attenuation.

SUPPLY AIR

SUPPLY AIR HOOD JSI

Jeven supply air columns deliver a controlled and flexible distribution of the supply air. It is possible to wash the supply air columns in a dishwasher and the inside of the supply air chambers is easy to clean.

Horizontal alignment of the supply air

The supply air blow direction can be aligned left or right by moving the air control plates inside the supply air units. The air control plates are marked in red in the pictures.

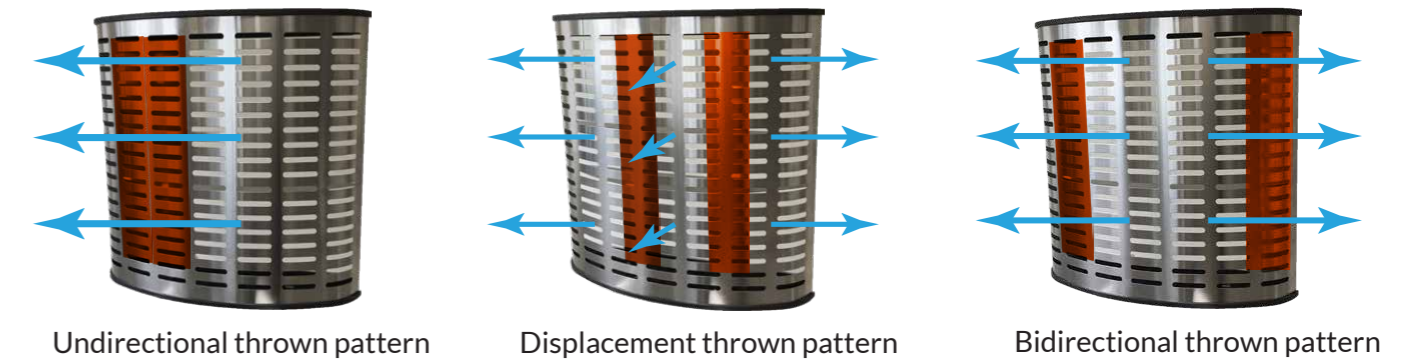

Vertical alignment of the supply air

The supply air blow direction can be aligned up or down by turning the horizontal air control plates inside the supply air units. The air control plates are marked in red in the pictures.

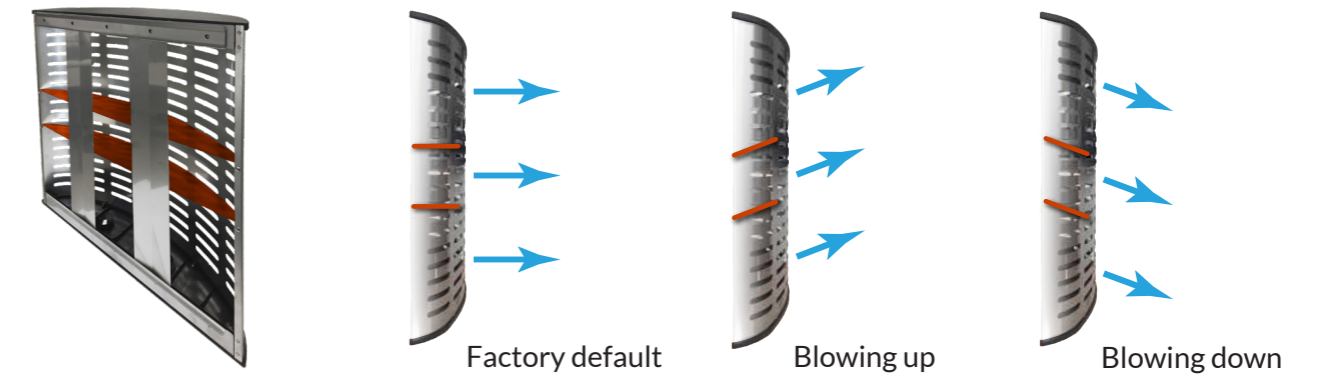

Air blow directions alignment nearby supply air column

Supply air blowing direction can be aligned by turning the rotatable blowing nozzles at the bottom of the supply air column. The rotatable nozzles are marked in red in the pictures.



SUPPLY AIR

SUPPLY AIR HOOD JSI

The canopies are supplied from the factory with suitable air flow rates for a pressure level of 25-35 Pa.

The amount of supply air/supply air unit

Hood height	Supply air unit width, B	
	200 mm	500 mm
330	-	50-90 l/s
540	40-70 l/s	100-150 l/s

Pressure loss, sound data & throw length/supply air unit

Spigot ø200 mm

Unit width 500 mm. Hood height 330 mm. Measurement after 90° curve.

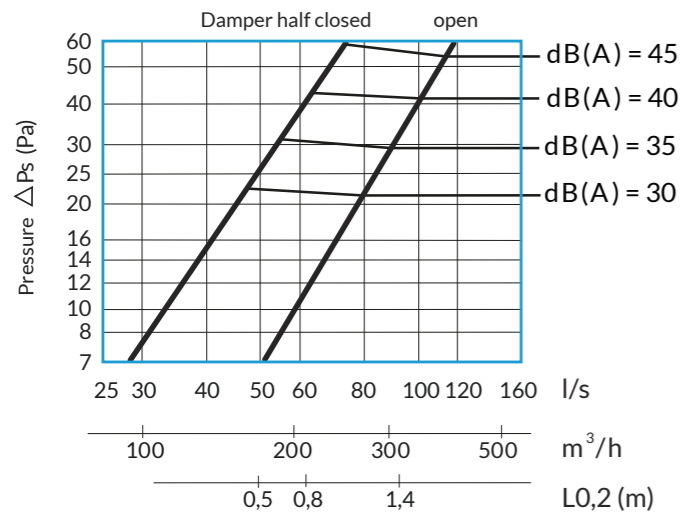

Spigot ø160 mm

Unit width 200 mm. Hood height 540 mm. Measurement after 90° curve.

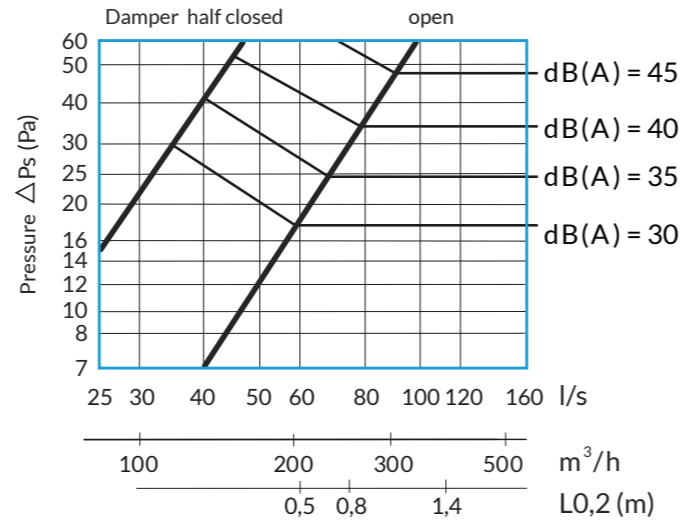

Spigot ø250 mm

Unit width 500 mm. Hood height 540 mm. Measurement after 90° curve.

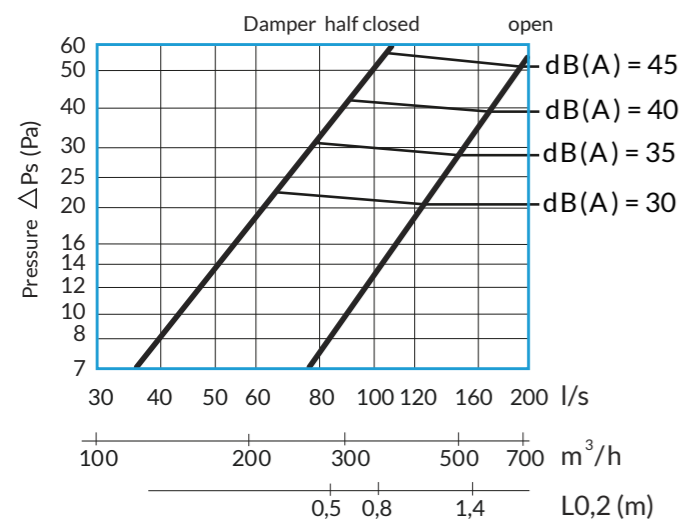

The sound power level (Lw) in each octave band is computed by adding the corresponding factor Kok to the sound pressure level (LpA), as in $Lw = LpA + Kok$

Spigot ø200

Hz	125	250	500	1000	2000	4000
Kok	-2	7	4	-5	-19	-26
tol.	±6	±4	±2	±2	±3	±5

Spigot ø160

Hz	125	250	500	1000	2000	4000
Kok	-2	1	2	1	-7	-16
tol.	±3	±3	±2	±2	±3	±4

Spigot ø250

Hz	125	250	500	1000	2000	4000
Kok	6	8	4	-5	-10	-18
tol.	±3	±3	±2	±2	±3	±4

LIGHTS

JCE HOODS

Every hood module comes with an energy efficient LED light fixture integrated to the hood's roof.

The light fixture has a cable which should be connected to a junction box with a cable lock. The connecting cable must be positioned in such way that it is not exposed to mechanical or thermal stress.

IP 66 integrated LED lamp
4000 K, CRI >84
inc 2 m HF-connection cable
(Halogen Free, type 3x1,5 mm²)



DIMENSIONS

SUPPLY AIR HOOD JSI

Wall hood

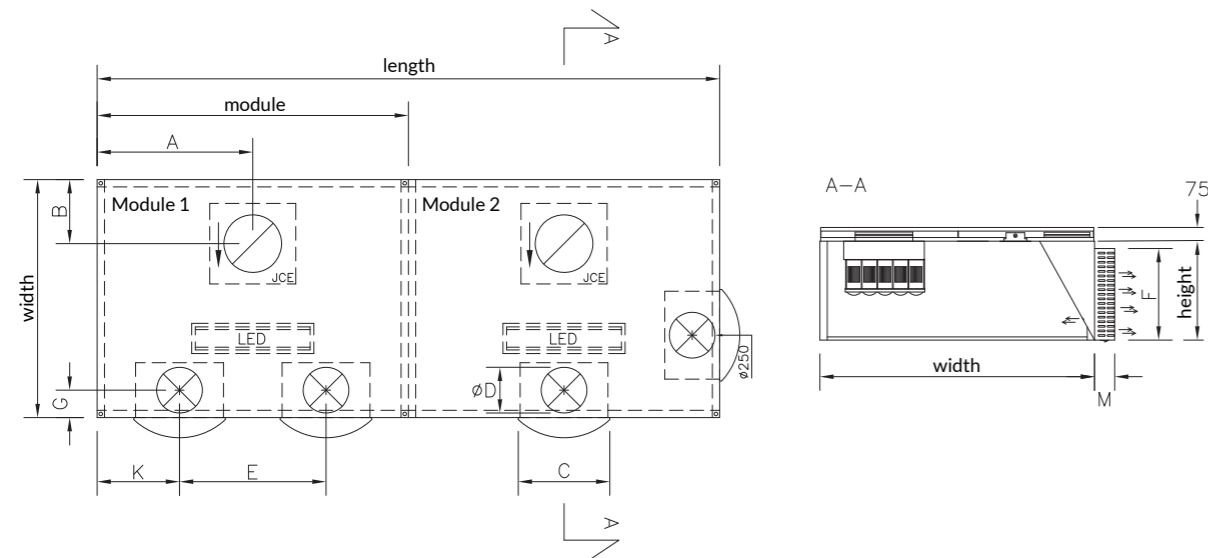

Island type hood

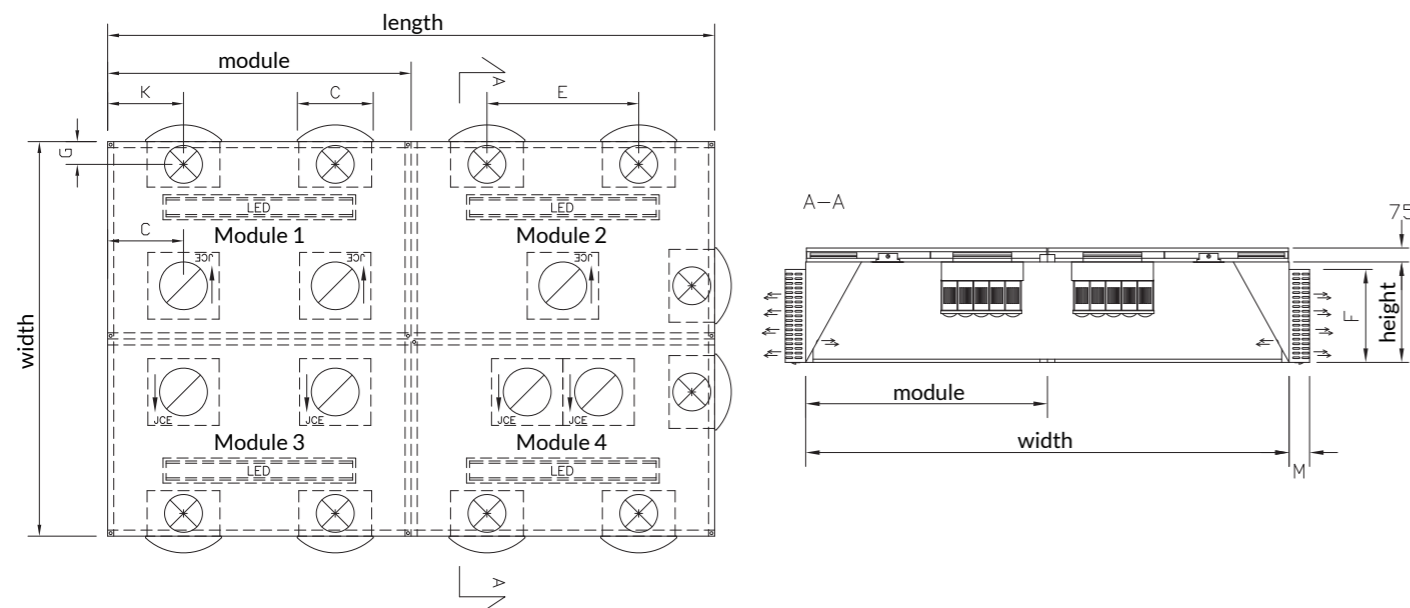

Hoods length and width can be chosen freely. Max. module size is 3000 mm x 1800 mm. All dimensions in millimeters (mm).

Hood height	C	F	øD	G	E min	K min	M
540	200	500	160	100	400	350	65
330	500	290	200	125	700	500	110
540	500	500	250	150	800	550	110

POSITIONING

The size of the canopy is determined by the size of the kitchen equipment.

As an edge overlay, it is recommended to 300 mm from the outside of the kitchen appliance. Above the side-opening devices, it is recommended to use a minimum of 400 mm edge overhang. Above the doors of opening or similar devices, it is recommended to have a door-to-edge overhang.

The recommended distance between the hood side and the floor is 2100–2200 mm.

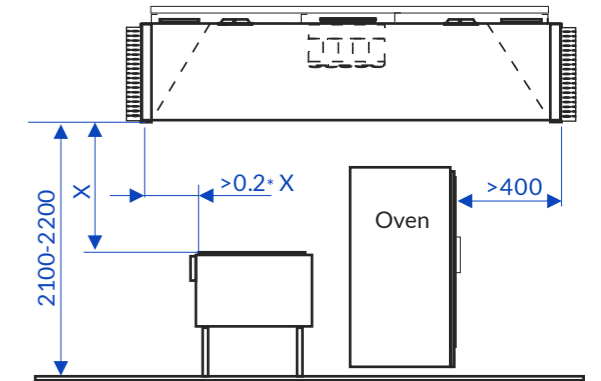

PRODUCT CODE

JSI- R - 3000 x 1500 x 540 - 6x250 - 3 x 315 + 750 l/s - 850 l/s - CB - FP

MODEL

JSI=Supply air hood
JLI=Exhaust air hood

MATERIAL

R=Stainless steel AISI 304
S=Laminated glass

SIZE

Length x Width x Height

EXHAUST AIR FLOW I/S

SUPPLY AIR FLOW I/S

NUMBER AND SIZE OF THE EXHAUST AIR CONNECTIONS

NUMBER AND SIZE OF THE SUPPLY AIR CONNECTIONS

ACCESSORIES

CB=Covering boards
FP=Ansul R102 extinguishing system

- Even JCE hoods come equipped with cyclonic JCE grease filters and integrated LED lights.
- The hood's base material is stainless steel AISI 304.
- The side panels can also be made of polycarbonate.

JEVEN DESIGNER SERVICE

You can have airflow calculations and project-specific product solutions quickly and easily for your project.

Our design service will provide a proposal for your project, including hood blocks in MagiCAD or CADS format as well as airflow calculations.

jeven.fi/en/designer-service >



Jeven
Top ventilation for top chefs