

Lindab**Assembly**

Lindab Roof drainage system™
Installation instructions

Roof drainage



Contents - guide

| | |
|--|----|
| Before you start | 3 |
| Introduction | 4 |
| | |
| Brackets, general | 6 |
| Brackets - distance and slope | 8 |
| Rafter brackets - various solutions..... | 10 |
| Rafter brackets - assembly..... | 11 |
| Fascia brackets - assembly | 15 |
| Brace for gutter bracket..... | 19 |
| | |
| Assembly of gutter system | 20 |
| Assembly of the gutter..... | 21 |
| Assembly of the gutter angle | 25 |
| Positioning the gutter in the bracket..... | 27 |
| | |
| Downpipes and bends..... | 28 |
| Assembly of the pipe holder | 32 |
| Drainage and collection of water..... | 36 |
| Other products | 39 |

Before you start

Transport, storage and unpacking

Make sure that the roof drainage components are handled carefully during transport, storage and unpacking. Failure to do so may result in damage to the coating or dents in downpipes and gutters.

Store downpipes and gutters on a flat and stable surface.

Unpainted components should be stored in a dry and well-ventilated environment.

Maintenance

If you want to keep your roof drainage system in the best condition, you should inspect it a few times a year. Clear gutters and pipes of leaves and twigs. Rinse with lukewarm water, mild detergent, soft brush. Do not use a high-pressure washer.

Fixing

The fasteners you need are the ones for attaching brackets and pipe holders to facades or eaves. We recommend that you always use stainless steel screws and screws that are suitable for the respective material. The pipe holder should be mounted on the facade of the house, and the fixing differs depending on whether the facade is brick, sheet metal, wood or render.



Don't forget to take care of and recycle off cuts and discarded parts! Steel can re-used over and over!

Tools

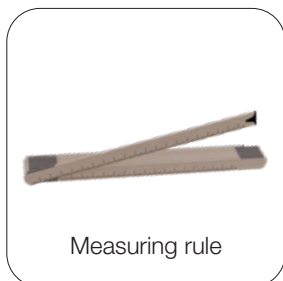

Measuring rule

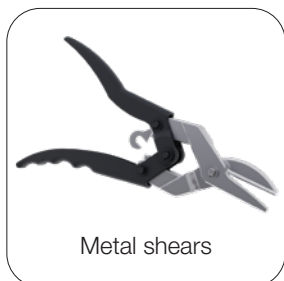

Metal shears



Drill and screwdriver



Rubber mallet



Spirit level

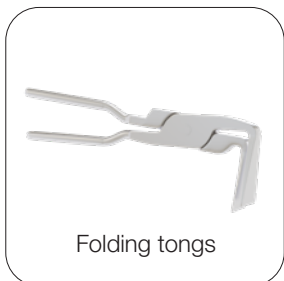

Folding tongs

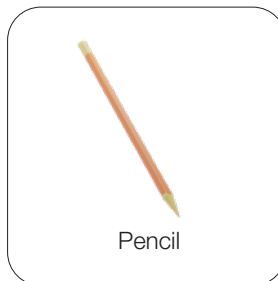

Pencil



Hacksaw



Do NOT use an angle grinder.

Cut gutters and pipes with metal shears or a hacksaw on a flat surface on the ground. Never use an angle grinder. It heats the steel and thereby destroys the galvanization. The coating can also be burnt by chips and grinding dust.

If the coating has been damaged, it must be painted with Lindab touch-up paint to preserve the service life of the entire roof drainage system. Use a sponge or Lindab touch-up pen.

Introduction

It is difficult to generalise when it comes to the design and dimensioning of roof drainage, even though there are industry standards to rely on. In recent years, we have seen that rain volumes increase in certain rainy periods and, above all, that the intensity of rain showers has increased both in terms of time and quantity. Adjacent topography, other buildings and the building's design can also influence the needs of the building in question. Combined, these factors mean that a property owner should - in addition to industry requirements - take into account the building's needs and vulnerability when dimensioning and designing the roof drainage system. Lindab has used the Swedish standard with a rainfall volume of 0.013 l/sqm.

Suspended gutter

Lindab has three different gutters to choose from:



Half-round Quarter round Rectangular

The gutter design, dimensions and inclination affect how it can cope with flooding and sludging. The slope of the gutter should be 2.5 - 5 mm/m.

Dimensioning of gutters and pipes

Storm water installations must be able to divert rainwater and meltwater so as to limit the risk of flooding, accidents or damage to buildings and land.

Rainwater installations can be designed in accordance with SS-EN 12056-1 and 12056-3. (BFS 2006:12)

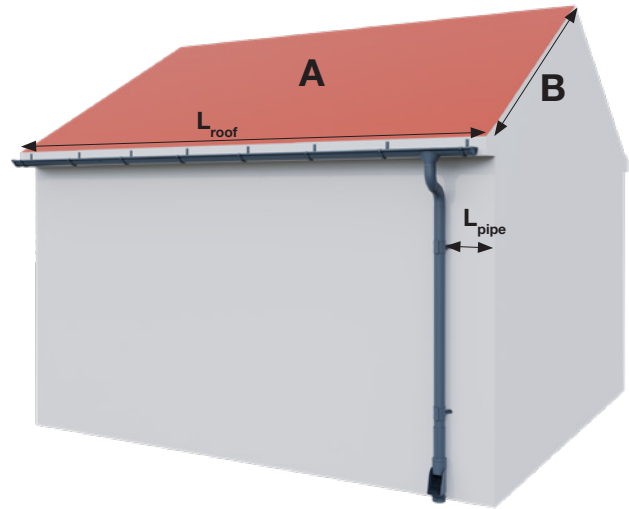

The area of the roof (the part you are dimensioning for) is calculated by

$$A = L_{\text{roof}} \times W$$

If there are multiple roofs of various sizes, each roof area must be calculated separately.

| My gutter | Max. roof area (one side) | | | | |
|---------------------|---------------------------|---------------------|---------------------|---------------------|---------------------|
| | ≤75 m ² | ≤125 m ² | ≤200 m ² | ≤275 m ² | ≤400 m ² |
| Half round R 190 | | | | | |
| Rectangular RER 136 | | | | | |
| Quarter round KVRA | | | | | |
| Half round R150 | | | | | |
| Half round R125 | | | | | |
| Half round R100 | | | | | |

Other things that may need to be taken into account when designing gutters:

- Are there any adjacent walls or ceilings that could increase the amount of rain on the roof in question?
- Roof Pitch
- How sensitive is the facade to overflow?
- Is the house in an especially rainy area?

Number of downpipes/outlets

Of course, the dimensions of the downpipe depend on the amount of water that needs to be removed. It matter if the gutter is large enough when the pipe doesn't have time to receive the amount of water - the gutter will still overflow. The problem can be solved in different ways: larger dimensions or more downpipes.

| Min downpipe | Max. roof area (one side) | | | | |
|--------------|---------------------------|--------------------|--------------------|--------------------|--------------------|
| | 75 m ² | 125 m ² | 200 m ² | 275 m ² | 400 m ² |
| DPIPE 120 | | | | | |
| DPIPE 111 | | | | | |
| DPIPE 100 | | | | | |
| DPIPE 87 | | | | | |
| DPIPE 75 | | | | | |

This table is based on 1 downpipe/side. If two downpipes are used, the design roof area is halved.



Regular apex roof:

As a rule of thumb, there should be a downpipe for every 10 m of gutter. In practice, this means that if one long side of the house exceeds 10 m, 2 downpipes/side are required.

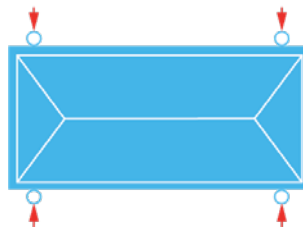

Hipped roof

Since the ends of the house also have gutters, 2 downpipes/side are usually required. However, there is nothing preventing one or more downpipes from being placed on the end.

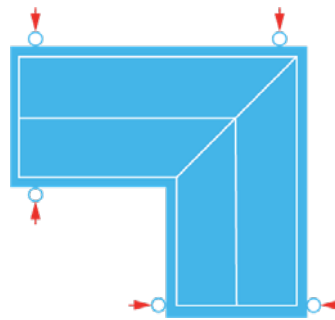

Corner building:

Here too, the gutters are usually so long that 2 downpipes/side are needed.

Brackets, general

Fascia

Depending on the design of the fascia, different types of brackets can be used. When selecting a gutter bracket, there are various aspects to consider:

- The appearance of the fascia - does it have a fascia board or not?
- If the bracket is mounted before the fascia sheet and wind deflectors

- Should the system have inner or outer angles? It is easier to install angles with metal brackets.

In general, it can be said that brackets with sheet metal fasteners are somewhat easier to install, as the snap fasteners require that the gutter can be compressed during insertion.

Fascia bracket



Fascia brackets are attached to a fascia board.

Fascia bracket



K07 (AK07*)

Fascia bracket with sheet metal attachment. For straight fascia board



KFK (AKFK*)

Fixed fascia bracket. For straight fascia board.



K11P

Short bracket with sheet metal attachment for sandwich panels.



K11

Inclined fascia bracket with sheet metal attachment. For fascia board inclined 27° to the vertical plane.



SKK

Adjustable fascia bracket with sheet metal attachment. For various roof pitches



KRD

Balcony bracket with sheet metal attachment.



RSKR

Gutter joint bracket



FRK

Gutter bracket for use when installing standing seam roofs.

* Aluminium

Rafter bracket



The rafter bracket is used for open fascia and attached to the top of the roof, except for the KRT, which is attached to the upper frame of the roof truss.

Rafter bracket



K18 (AK18*)
Rafter bracket with sheet metal attachment.



K21
Rafter bracket with sheet metal attachment.



K33
Rafter bracket with sheet metal attachment. Extra long.



KFM
Fixed rafter bracket.



KFL
Fixed rafter bracket. Long

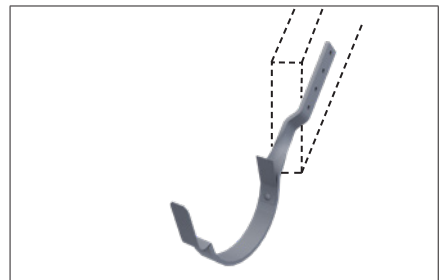

KRT
Upper frame bracket with sheet metal attachment. For mounting on the upper frame of the roof truss (feet).

Miscellaneous



BRACE
Reinforcement of gutter.

* Aluminium

Bracket distance and slope

Regardless of the type of bracket used, they must be mounted so that the gutter has slope of at least 2.5 mm/m towards the downpipe. The greater the gutter's slope, the better the self-cleaning that is achieved. The brackets must be mounted at max. cc 600 mm.

Calculate the slope f (mm) by $f = 0.0025 \times L$

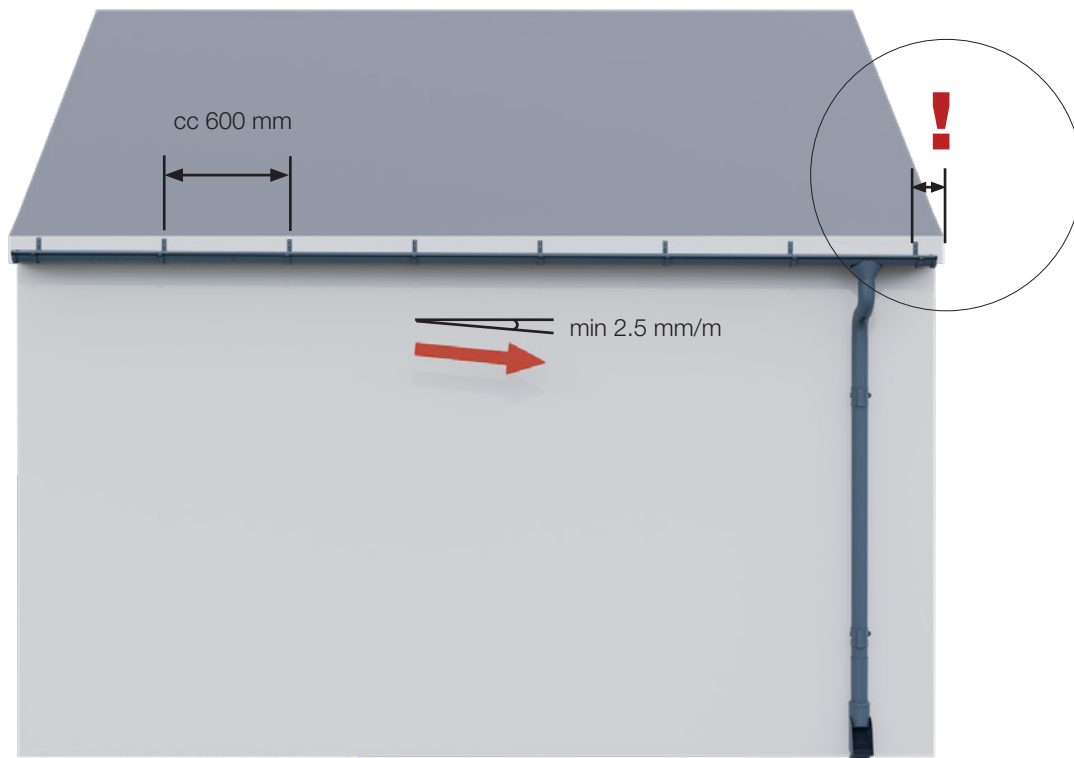

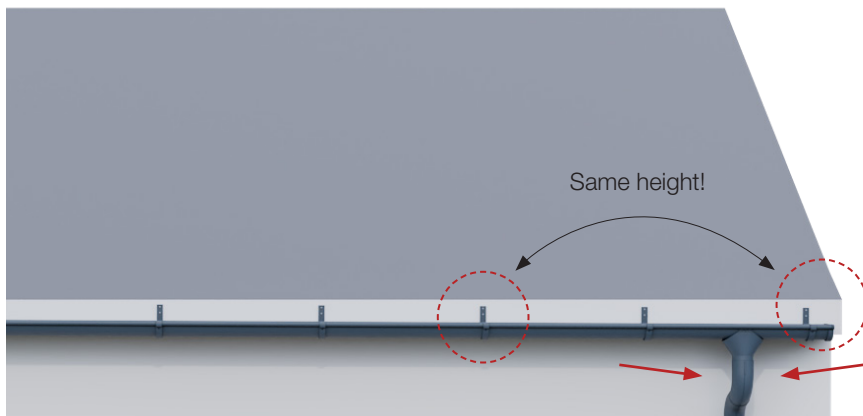

In order to prevent water from collecting on the outside of the gutter outlet, the gutter must have a slight slope back towards the outlet. To achieve this, position the last bracket (in the picture right of OMV) at the same height as the second to last bracket before the cup.

! Outer edge solution

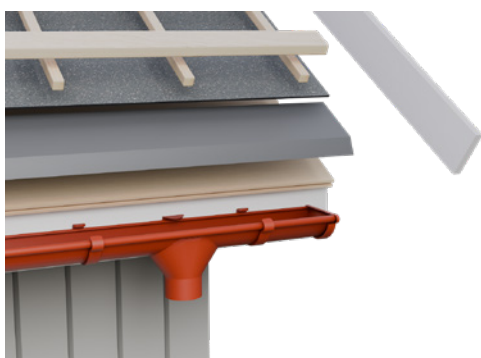

The ideal procedure for installation is to install brackets and gutters with gutter outlet and gutter ends before installing foot eaves sheet and bargeboard, as they will otherwise be in the way. If you already have an eaves sheet and bargeboard installed, you need to take this into account when selecting the bracket and assembly.

In theory, there is nothing preventing you from placing the first (or last) bracket all the way out against the bargeboard. However, there may be some practical problems if there are bargeboards and cover the gutter end. The gutter end must then be mounted on the gutter before the gutter is placed in the bracket.

If you have chosen a bracket with a sheet metal attachment, this is not a problem, but if you have a bracket with a snap-on attachment, the gutter must be squeezed together slightly to be able to be pressed into place. In these cases, the distance to the first bracket must be 200 mm from the gutter end, which otherwise impedes the flexibility of the gutter.

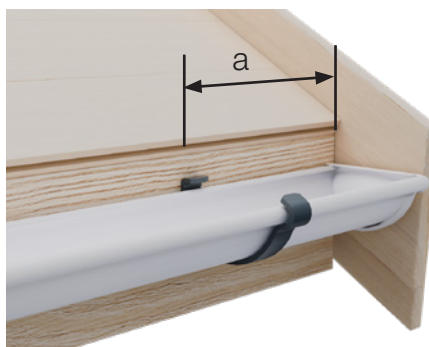

So the distance

a for sheet metal attachment = 0-100 mm

a for snap-on attachment = 200 mm

(K07, K11, K11P, SKK, KR D, K18, K21, K33, KRT)

(KFK, KFM, KFL)

Rafter brackets - various solutions

Eaves with eaves wedge (e.g. for concrete or slate tiles)



For roofs to be covered with slate or concrete tiles, eaves wedges are a common solution at the eaves. The brackets are then milled into the eaves wedge:

- tiles - supporting battens/counter-battens
- underlay
- eaves sheet
- eaves eaves sheet underlay
- bracket
- eaves wedge
- tongue and groove board (20 mm)

Eaves with batten and double eaves sheet (e.g. for sheet metal roof)

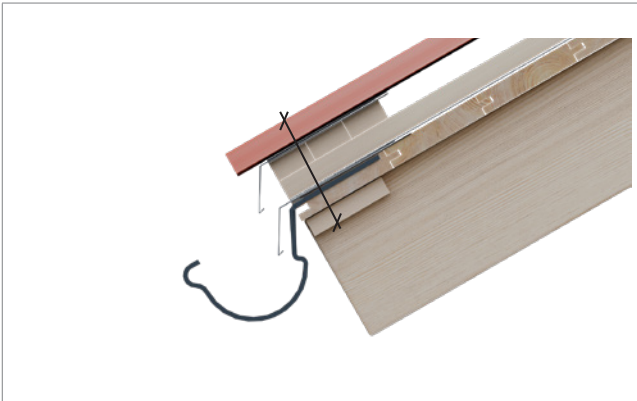

For roofs where the roof covering is to be laid on battens, but where an eaves wedge cannot be used, double eaves sheets should be used. The bracket is then milled into the tongue and groove board. A reinforcement board can be laid under the tongue and groove board to reinforce the attachment of the bracket. To underpin the upper eaves sheet, three counter-battens can be laid together along the eaves.

- sheet metal or similar
- eaves sheet underlay/eaves sheet/eaves sheet underlay
- batten
- counter-batten
- underlay/eaves sheet/eaves sheet underlay
- bracket
- tongue and groove board (min. 20 mm)
- reinforcement board

Options for eaves with battens and double eaves sheet (e.g. for sheet metal roofs)

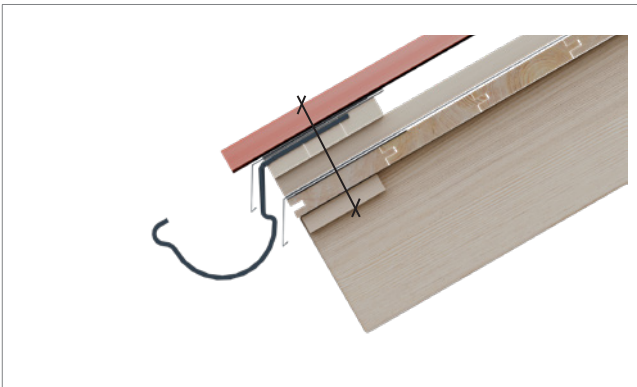

For roofs where the roof covering is to be laid on battens, but where an eaves wedge cannot be used, double eaves sheets should be used. The bracket is milled into the support batten. A reinforcement board can be laid under the tongue and groove board to reinforce the attachment of the bracket. To underpin the upper eaves sheet, three counter-battens can be laid together along the eaves.

- sheet metal or similar
- eaves sheet underlay/eaves sheet/ eaves sheet underlay
- support batten
- bracket
- counter-batten
- underlay/eaves sheet/eaves sheet underlay
- tongue and groove board (min. 20 m)
- reinforcement board

Eaves without battens (e.g. profiled sheet metal roof or felt roof)



For roofs where the roof covering is laid directly on tongue and groove board/felt and no battens are to be used, the bracket needs to be milled down into the tongue and groove board. A reinforcement board can be laid under the tongue and groove board to reinforce the attachment of the bracket.

- sheet metal, felt or similar
- underlay
- eaves sheet
- eaves sheet underlay
- bracket
- tongue and groove board (min. 23 mm)
- reinforcement board

Rafter brackets - assembly

Fascia with fascia wedge (e.g. for concrete or slate tiles)

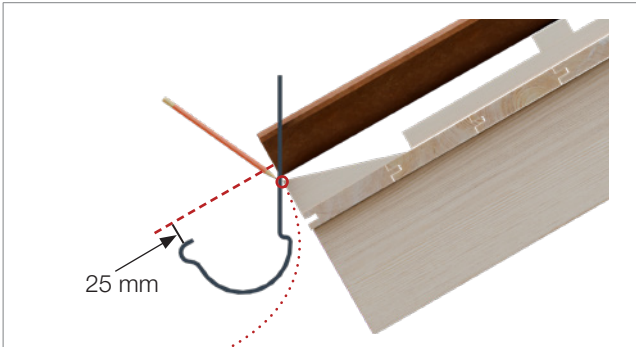

Measure a line from the finished roof (dotted line) and hold the first gutter bracket 25 mm below. Draw a line on the bracket where it will be bent at the fascia wedge. This is bracket No. 1 in the picture below and the highest bracket, which is farthest from the downpipe.

Calculate the slope f (mm) by $f = 0.0025 \times L$ where L is the length between the first and last bracket.

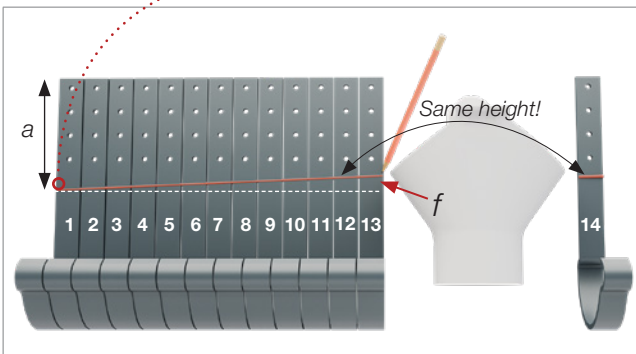

Put the brackets together and draw a line to get the slope. Starting from the line on bracket No. 1. Take the distance a - distance f (see previous page) and mark it on the last bracket before the gutter outlet (no. 13 in the illustration). Put all the brackets together, except the one on the other side of the downpipe, and draw a line. Bracket No. 13 is the lowest bracket and is located closest to the downpipe. In our example, bracket No. 14 should have the same height as bracket No. 12, to get a slight slope back towards the downpipe.

One tip is to number the brackets so that they end up in the correct order.



Bend all the brackets at the correct angle for the roof where the marking is.



For a good result, the brackets should be milled down in the fascia wedge. The brackets are fastened with countersunk wood screws.



Cover with fascia sheet underlay.



Attach the fascia sheet and then lay the underlay.

Rafter brackets - assembly

Eaves with batten and double eaves sheet (e.g. for sheet metal roof)

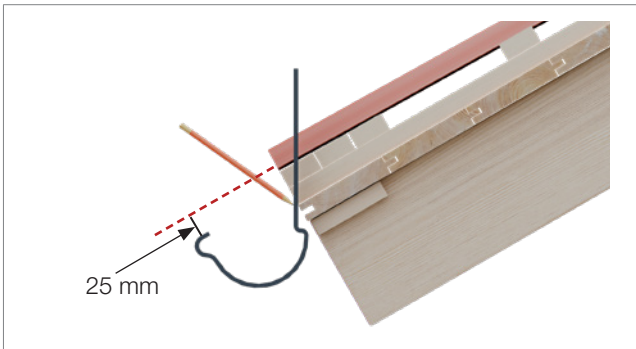

Measure a line from the finished roof (dotted line) and hold the first gutter bracket 25 mm below. Draw a line on the bracket where it will be bent at the eaves wedge. This is bracket No. 1 in the picture below and the highest bracket, which is farthest from the downpipe.

Calculate the slope f (mm) by $f = 0.0025 \times L$
where L is the length between the first and last bracket.

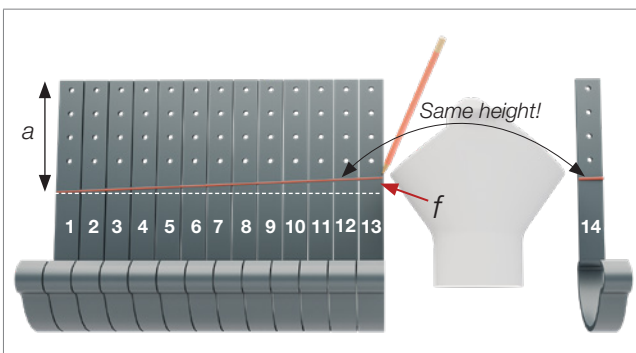

Put the brackets together and draw a line to get the slope. Starting from the line on bracket No. 1. Take the distance a - distance f (see previous page) and mark it on the last bracket before the gutter outlet (no. 13 in the illustration). Put all the brackets together, except the one on the other side of the downpipe, and draw a line. Bracket No. 13 is the lowest bracket and is located closest to the downpipe. In our example, bracket No. 14 should have the same height as bracket No. 12, to get a slight slope back towards the downpipe.

One tip is to number the brackets so that they end up in the correct order.



Bend all the brackets at the correct angle for the roof where the marking is.



For a good result, the brackets should be milled into the tongue and groove board. A reinforcement board can be laid under the tongue and groove board to reinforce the attachment of the bracket.



Secure the brackets with wood screws.



Lay a strip of eaves sheet underlay.



Attach the eaves sheet and then lay the underlay over the entire roof.



Lay counter-battens and support battens at least 25 x 45 mm. To underpin the upper eaves sheet, three counter-battens can be laid together along the eaves.



Cover the three support battens with eaves sheet underlay.

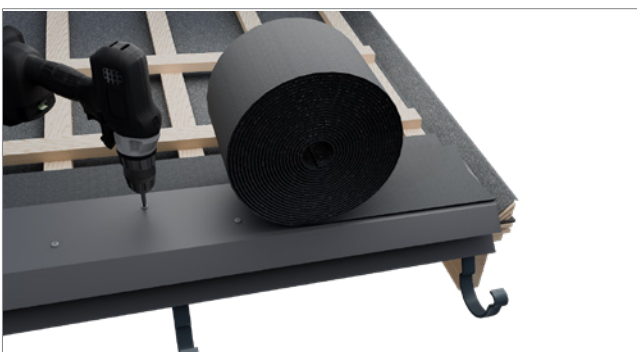

Then lay the upper eaves sheet and cover it with eaves sheet underlay.

Rafter brackets - assembly

Eaves without battens/wedges (e.g. for sheet metal or felt roofs)

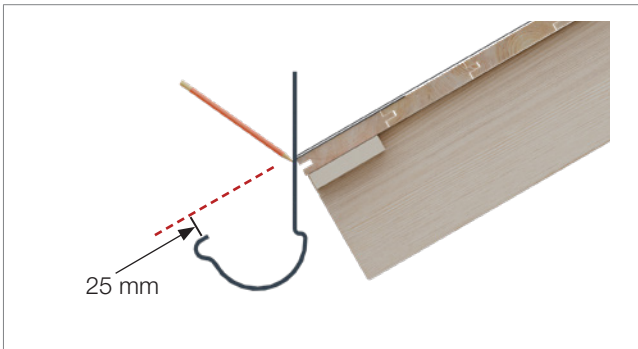

Measure a line from the finished roof (dotted line) and hold the first gutter bracket 25 mm below. Draw a line on the bracket where it will be bent at the eaves wedge. This is bracket No. 1 in the picture below and the highest bracket, which is farthest from the downpipe.

Calculate the slope f (mm) by $f = 0.0025 \times L$ where L is the length between the first and last bracket.

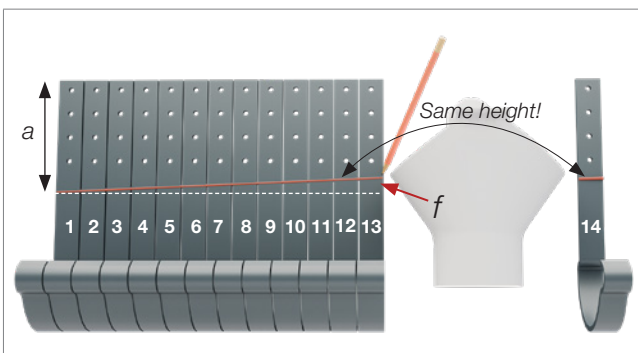

Put the brackets together and draw a line to get the slope. Starting from the line on bracket No. 1. Take the distance a - distance f (see previous page) and mark it on the last bracket before the gutter outlet (no. 13 in the illustration). Put all the brackets together, except the one on the other side of the downpipe, and draw a line. Bracket No. 13 is the lowest bracket and is located closest to the downpipe. In our example, bracket No. 14 should have the same height as bracket No. 12, to get a slight slope back towards the downpipe.

One tip is to number the brackets so that they end up in the correct order.



Bend all the brackets at the correct angle for the roof where the marking is.



For a good result, the brackets should be milled into the tongue and groove board. A reinforcement board can be laid under the tongue and groove board to reinforce the attachment of the bracket.



Attach the brackets with wood screws and lay a strip of eaves sheet underlay.



Attach the eaves sheet and then lay the underlay over the entire roof.

Fascia brackets - assembly

Fascia with straight fascia board

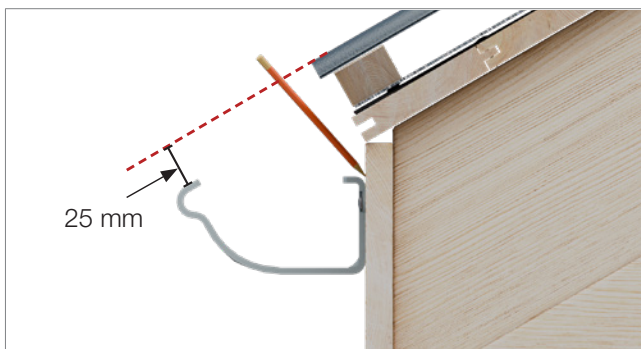

Measure a line from the finished roof (dotted line) and hold the first gutter bracket 25 mm below. This is bracket No. 1, which is the highest bracket and farthest from the downpipe.



Starting from the first height mark, draw a line with a slope of at least 2.5 mm/m up to the last bracket where the downpipe is to be located. See also section "distances and slopes".

Calculate the slope f (mm) by $f = 0.0025 \times L$ where L is the length between the first and last bracket.



Screw on the brackets with c/c max 600 mm. The brackets are fastened with countersunk wood screws.



Lay a strip of fascia sheet underlay.



Install the fascia sheet and then lay the underlay.

Fascia brackets

Fascia with fascia board 27°

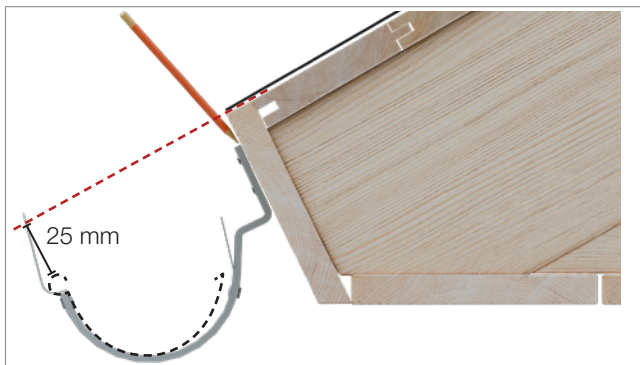

Measure a line from the finished roof (dotted line) and hold the first gutter bracket 25 mm below. This is bracket No. 1, which is the highest bracket and farthest from the downpipe.



Starting from the first height mark, draw a line with a slope of at least 2.5 mm/m up to the last bracket where the downpipe is to be located. See also section "distances and slopes".



Screw on the brackets with c/c max 600 mm. The brackets are fastened with countersunk wood screws.



Lay a strip of fascia sheet underlay.



Install the fascia sheet and then lay the underlay.

Fascia brackets

Adjustable fascia bracket

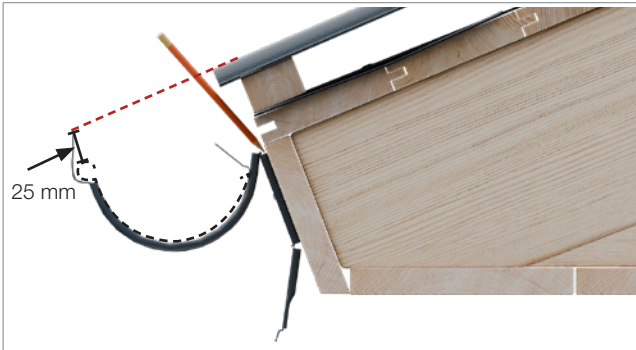

The adjustable fascia bracket is mounted on an fascia board, and can be adjusted for different roof pitches. It is important that the gutter is at the right height so that the water from the roof does not miss the gutter. Measure a line from the finished roof (dotted line) and hold the first gutter bracket 2-3 mm below and draw a line on the fascia board. This is bracket No. 1 and the highest bracket, which is furthest from the downpipe.

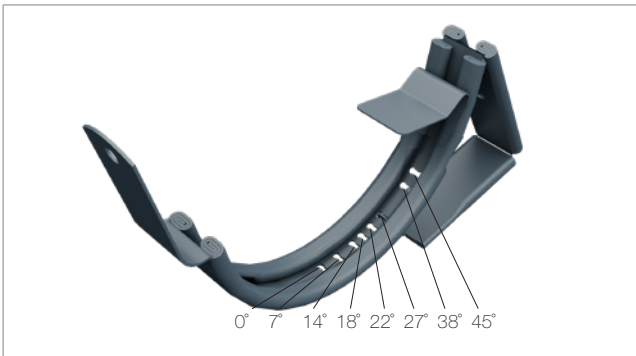

The adjustable bracket SKK can be adjusted for different roof pitches.

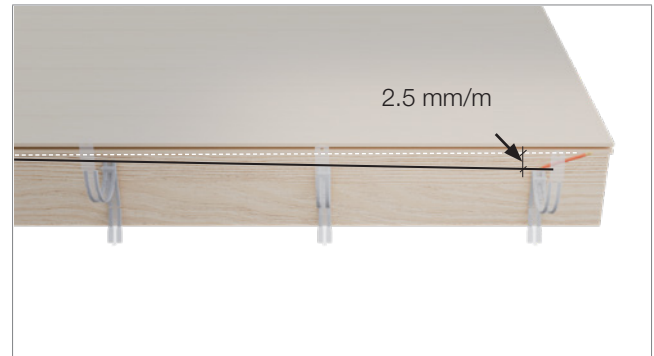

Starting from the first height mark, draw a line with a slope of at least 2.5 mm/m to the last bracket where the downpipe is to be located.



Attach the bracket to the fascia board with wood screws.



Bend the bracket down.



Bend the angle brace up to the correct hole.



Fold down the flap with a flat screwdriver (slotted screwdriver) to lock the angle brace. For angles >22°, push the flap backwards. For angles <22°, push the flap forward.

Fascia brackets

Gutter joint bracket for curved roof

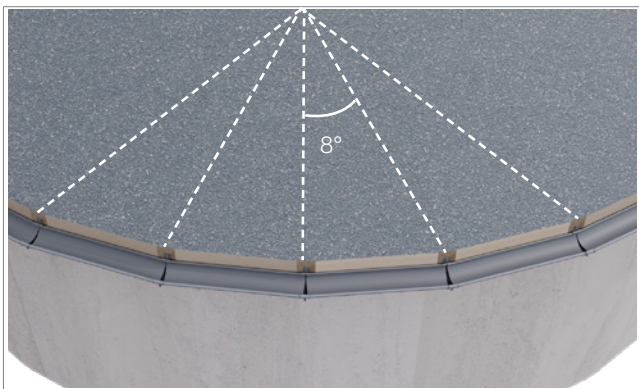

The gutter joint bracket can be used for bay windows and curved roofs with an angle of max. 8°.



The gutter joint bracket is attached to a straight fascia board or a straight-cut truss.

Measure a line from the finished roof (dotted line) and hold the first gutter bracket 25 mm below. This is bracket No. 1, which is the highest bracket and farthest from the downpipe.



Mark the height of the brackets and make sure that the height difference is at least 2.5 mm/m and is sloped towards the downpipe. Fasten the gutter joint brackets with wood screws.

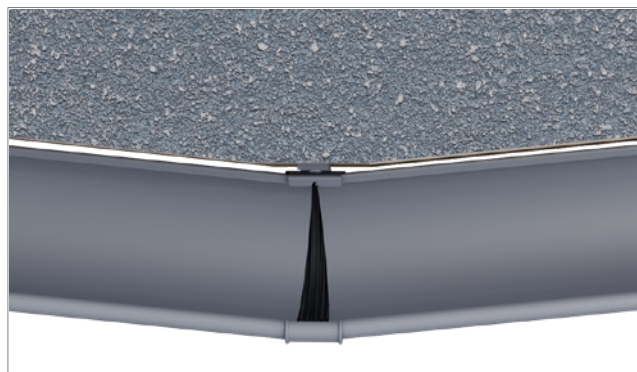

The gutter must not be cut at an angle, but rather laid with straight sides in the gutter joint angle.



Place the gutters (max. length 0.6 m) in the gutter joint bracket.



Fold the locking mechanism around and lock with the locking pin.

Brace for gutter bracket

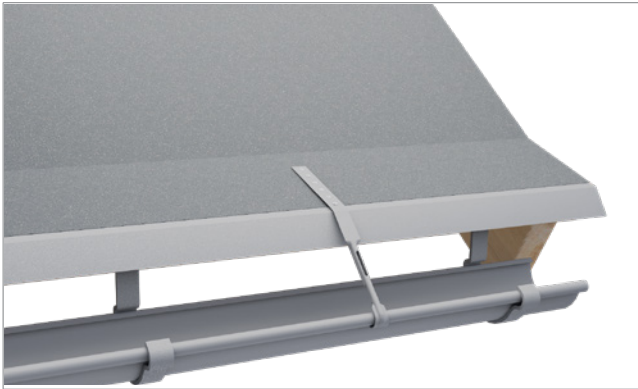

If there is a risk of heavy snow loads, a brace can be mounted between the brackets to protect the gutter from snow.



The brace can be bent and adapted to the shape of the eaves. Screw the brace into the tongue and groove board, eaves wedge or battens.

Installation of gutter system

Plan the work carefully. It can be difficult to access the eaves, but it is important that all the parts are correctly positioned to ensure a tight seal. If it is possible to wait with bargeboards until after installation, this is an advantage.



1. Installation of gutter

Making holes in gutter

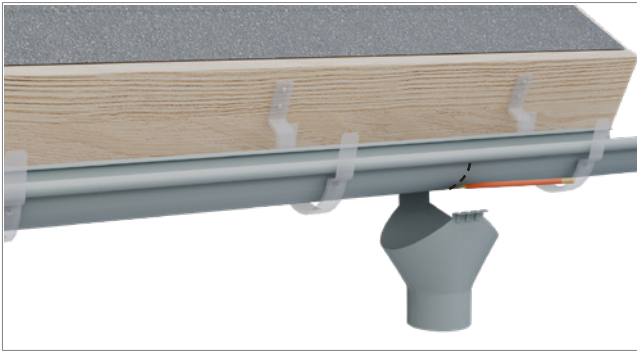

Mark on the gutter where the gutter outlet is to be placed.

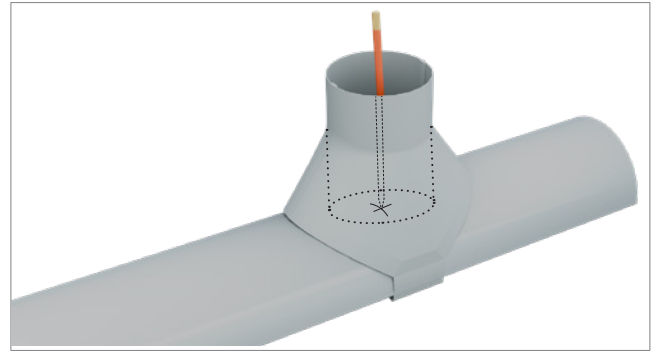

Mark where on the gutter the downpipe should be.

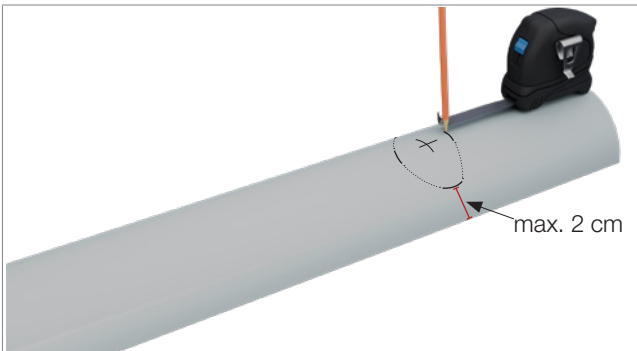

Measure a hole that is at least as wide as the downpipe. The hole may be slightly oblong, but leave an edge of max. 2 cm from the edge of the gutter.

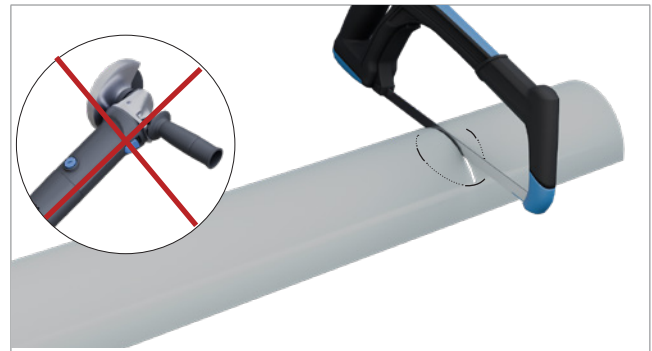

Using a hacksaw, cut a notch in the centre of the mark.



Split the cut edges with a chisel or pliers to gain access with the sheet metal shears. Use a pair of metal shears to cut the edge of the hole.

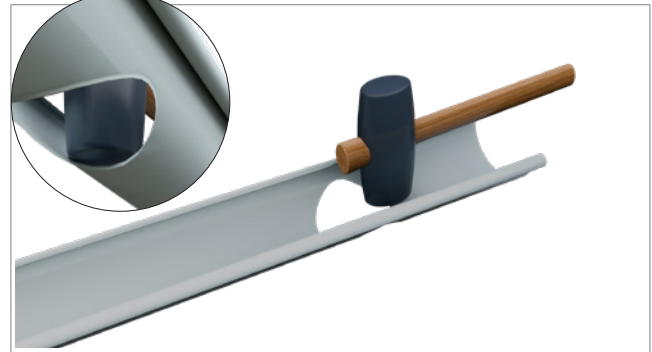

Smooth the edges with a hammer or plastic mallet, so that the edges are bent slightly downwards.



Insert the edge of the outlet into the bead of the gutter at the front edge.



Click the outlet into place at the rear edge.

Gutter end RG



Cut off the flap of the gutter end that is facing in towards the fascia. If you have an open fascia and the entire gutter end can fit, the flap can be left in place if desired.

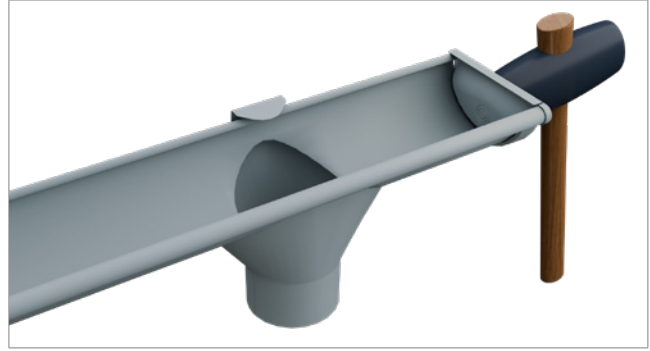

Tap the gutter end panel onto the gutter. Use a plastic mallet to tap in the end piece. Start at the front and work around the gutter end.

Gutter end RGU



Cut off the edge on the side facing the house wall.



Fold up the edge of the gutter slightly to make it easier to fit the gutter end.



Draw a bead of sealant in the gutter.

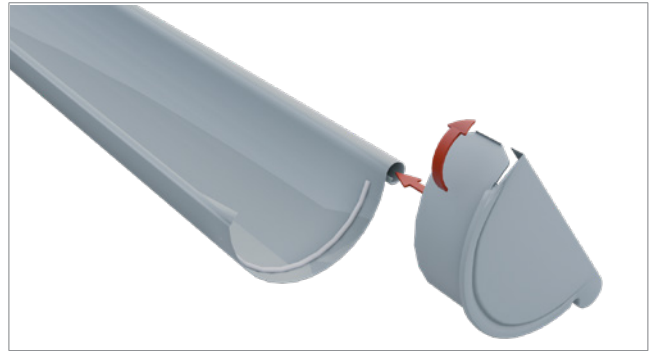

Tilt up the gutter end panel and slide it onto the gutter.



Fold down the gutter end panel in place.



Fold back the edge of the gutter.

Gutter end RGUT



Cut off the edge on the side facing the house wall.

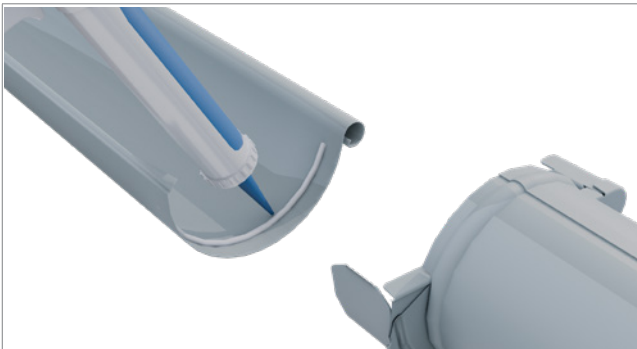

Draw a bead of sealant in the gutter.

The gutter end shoe can be used on roofs where the drainage from the gutter needs to go out to an adjacent roof instead of through a downpipe.

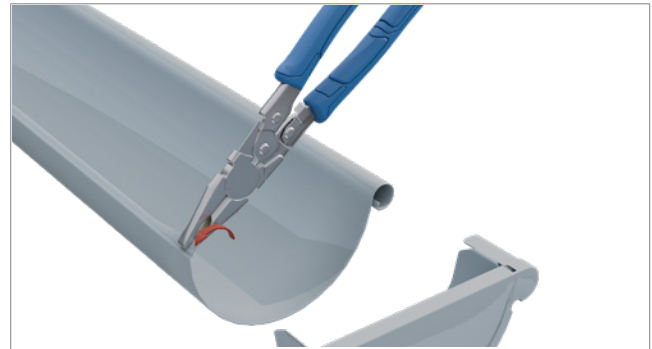

Fold up the edge of the gutter slightly to make it easier to fit the gutter end.



Tilt up the gutter end panel and slide it onto the gutter.

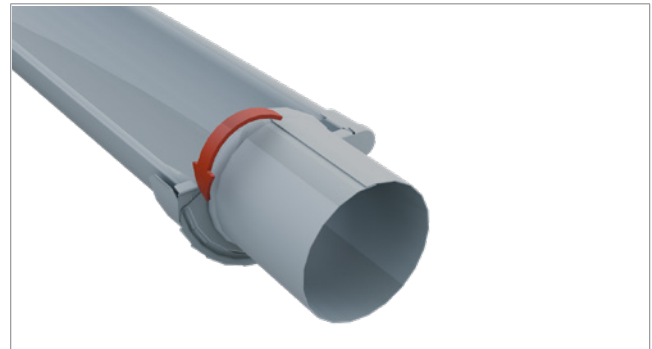

Fold down the gutter end panel in place.

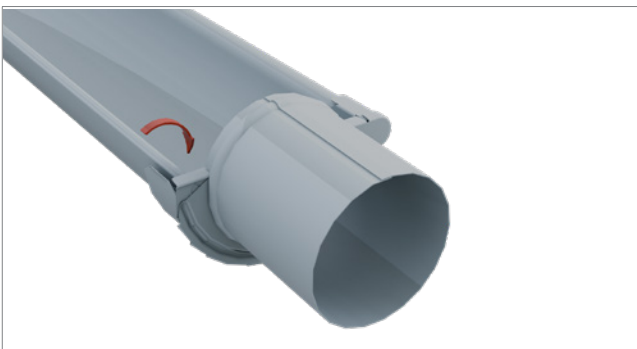

Fold back the edge of the gutter.



Joining of gutters

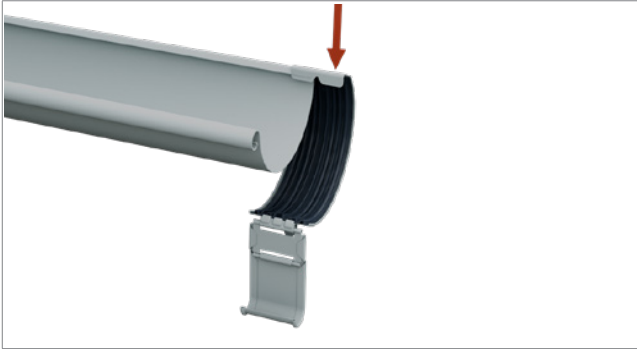

The easiest way to join the gutter is to use a gutter joint RSK. When one gutter is in place, the gutter joint is bracketed on at the rear edge.



Position the next section. The gutter joint's gap at the rear indicates how much space there should be between the gutters to allow them to expand in the event of temperature differences.



Push the gutter joint up by hand (do not use the locking mechanism to pull it into place).

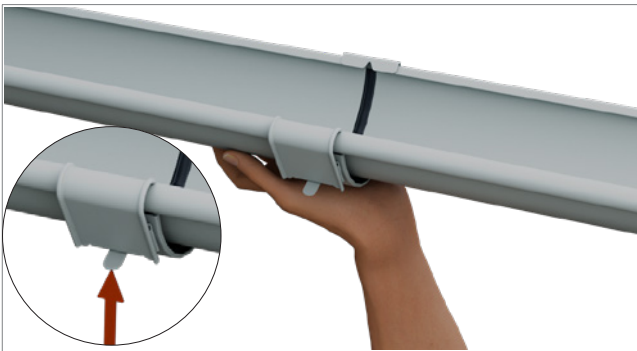

Fold the locking mechanism around and lock with the locking pin.

2. Installation of gutter angle

Outer gutter angle

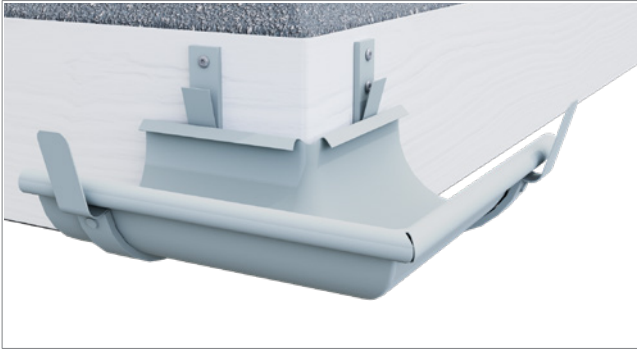

To facilitate the installation of the outer gutter angle, we recommend using an fascia bracket (where possible) or a short rafter bracket so that the rafters do not collide with each other on the roof. We also recommend the use of a bracket with a sheet metal attachment. Each gutter angle should have two brackets - one on each side of the angle.



Hang the gutter joints on the gutter angle and then place the gutter there. Refer also to the section on joining gutters. The distance a should be approx. half the inner length of the bracket. The distance b must not exceed 600 mm.

Inner gutter angle

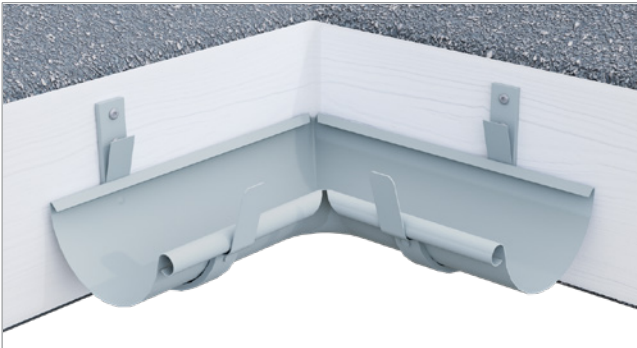

To facilitate the installation of the inner gutter angle, we recommend the use of a bracket with sheet metal attachment. Each gutter angle should have two brackets - one on each side of the angle.



Hang the gutter joints on the gutter angle and then place the gutter there. Refer also to the section on joining gutters. The distance a should be approx. half the outer length of the bracket. The distance b must not exceed 600 mm.

Installation of outer angle in fixed gutter bracket



To facilitate the installation of the outer gutter angle, we recommend a bracket with sheet metal attachment. When installing the outer bracket and fixed bracket, start by moving the inner edge of the bracket against the inner counterhold of the bracket.

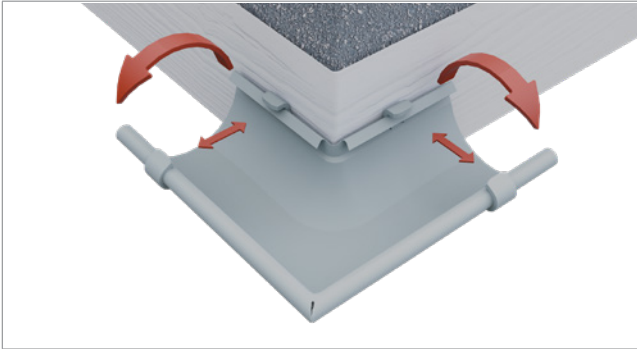

Squeeze the gutter angle as far as it will go and turn the angle back so that the angle of the outer bead comes inside the outer counterhold of the bracket.

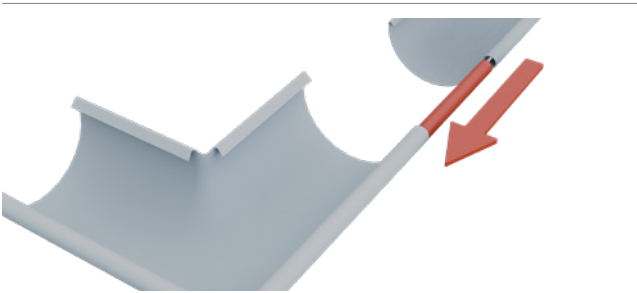

A reinforcement pipe can be used to reinforce the gutter angle. The pipe is inserted into the gutter angle and the gutter bead.

Installation of inner angle in fixed gutter bracket

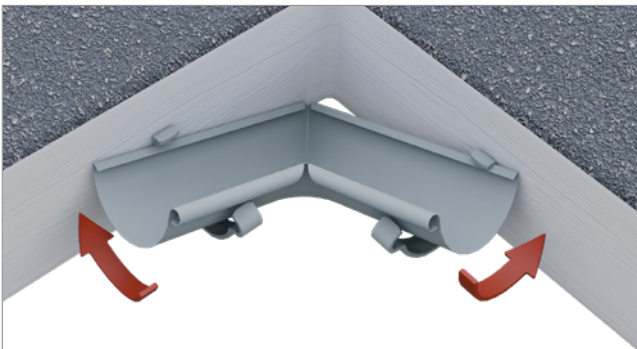

To facilitate the installation of the outer gutter angle, we recommend a bracket with sheet metal attachment. When installing the outer bracket and fixed bracket, start by moving the inner edge of the bracket against the inner counterhold of the bracket.

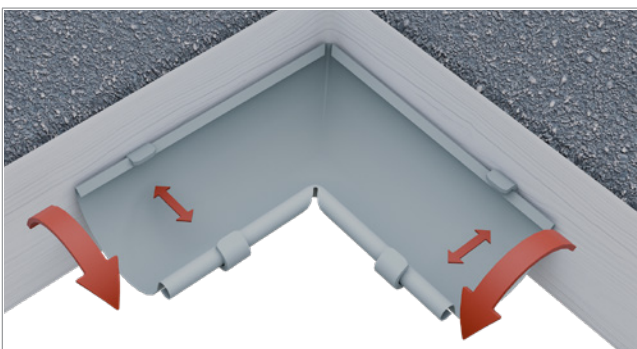

Squeeze the gutter angle as far as it will go and turn the angle back so that the angle of the outer bead comes inside the outer counterhold of the bracket.

3. Place the gutter in the bracket.

Brackets with sheet metal attachment



Place the gutter in the bracket.

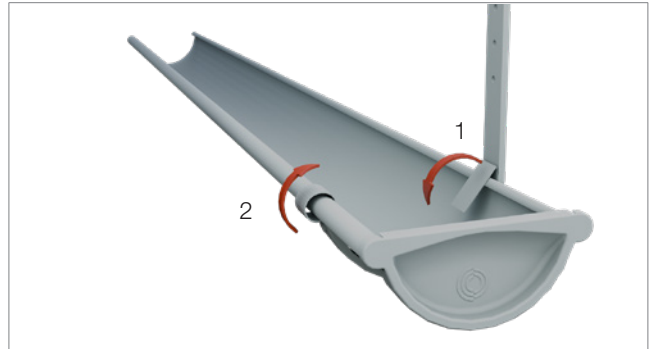

Fold the sheet metal over the gutter. Start with the sheet metal at the rear edge and then fold the front sheet around the gutter bead.

Fixed brackets - installation without fascia sheet



If the fascia sheet is not in place, it is easiest to insert the gutter in the front edge of the bracket first.



Press the gutter slightly together and twist the gutter down into the bracket lock at the rear edge.

Fixed brackets - installation with fascia sheet



If the fascia sheet is in place, it is easiest to first insert the gutter in the rear edge of the bracket under the fascia sheet or rigid felt support tray.

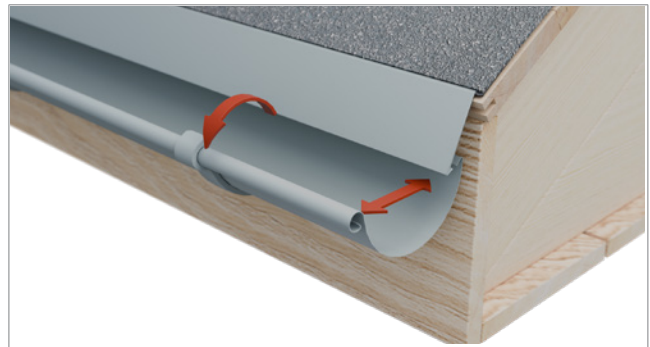

Press the gutter slightly together and twist the gutter down into the bracket lock at the front edge.

4. Downpipes and bends

Joining of downpipes

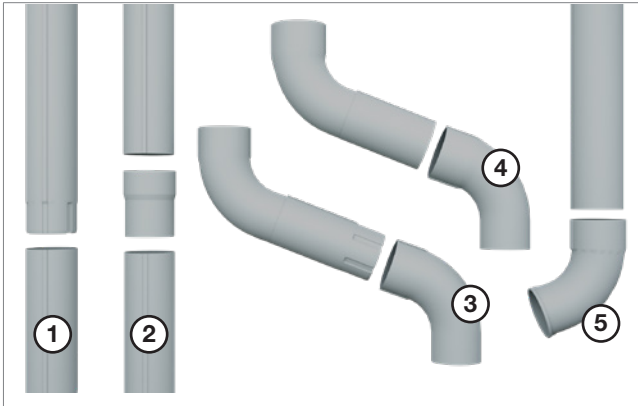

1. **Pipe – pipe.** When two downpipes are to be joined together, the crimped part of the upper pipe is used to fit into the uncrimped part of the lower pipe.
2. **Pipe – SRORM – pipe.** When two downpipes are to be joined together and there is no tapered part, the pipes can be joined with a downpipe sleeve DPIPEM.
3. **BK - pipe - BK.** When an adapter (MST or ROR) is used together with bends BK, the tapered part of the pipe needs to be fitted into the lower bend.
4. **BKM – pipe – BKM.** When an adapter (MST or ROR) is used together with bends BKM, the pipe should not have any tapered part.
5. **Pipe – UTK.** When installing with end shoe UTK, the pipe must not have any tapered parts (i.e. when cutting, the tapered part must cut off).

Joining of bend BK

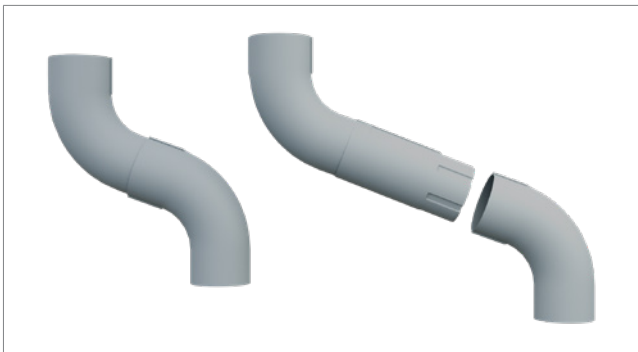

Bend BK can be joined BK – BK, or together with an intermediate piece with tapered part.

Joining of bend BKM

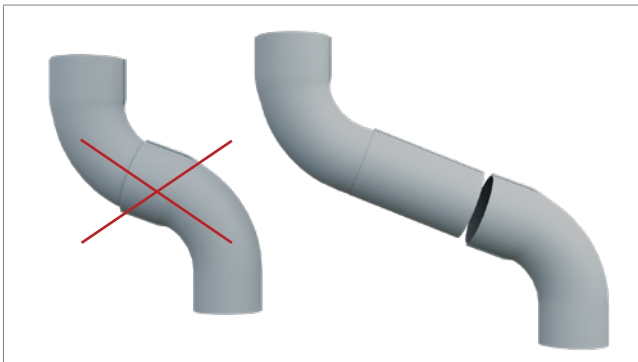

Bend BKM should not be joined with itself, as the sleeved part makes the coupling leaky. Instead, BKM should be used with an intermediate piece without a tapered part.

Different angles on bend BK

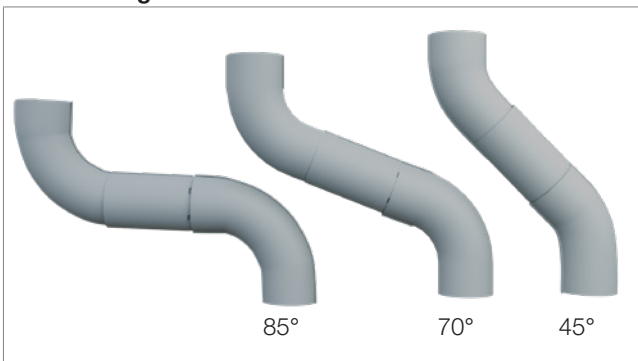

There are different angles on bend BK. The most common is 70°, but 85° is ideal for extra-long roof overhangs and 45° for extra-short roof overhangs.

Intermediate pipe

| U (mm) | L mm |
|--------|-------|
| 220 | 0 |
| 270 | 100 |
| 300 | 135 |
| 350 | 185 |
| 400 | 240 |
| 450 | 290 |
| 500 | 345 |
| 550 | 400 |
| 600 | 455 |
| 650 | 505 |
| 700 | 560 |
| 750 | 610 |
| 800 | 665 |
| 850 | 720 |
| 900 | 770 |
| 950 | 825 |
| 1,000 | 880 |
| 1,050 | 930 |
| 1,100 | 985 |
| 1,150 | 1,040 |
| 1,200 | 1,090 |

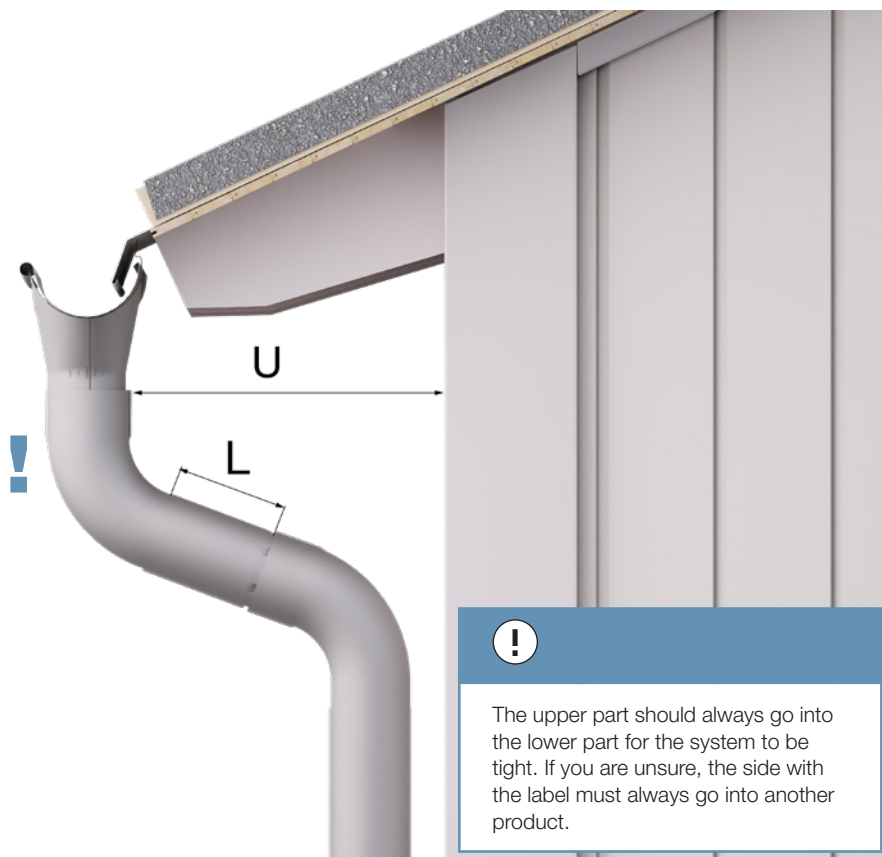

Cutting the intermediate pipe



Measure how long the intermediate pipe should be. The length of the intermediate pipe should be the distance between the bends + 100 mm (as the parts go into each other approx. 50 mm on each side). If you hold your hand between the wall and measure, you get a pretty good measurement (about 25 mm), but you can also use the table above as a guide.

Make sure to mark where the lower bend ends in order to be able to use that mark to measure the top pipe holder.



Cut the intermediate pipe to the correct length with a metal saw. If bend BK is to be used, save the tapered end, if bend BKM is to be used, cut off the tapered end.

Downpipe length and positioning of pipe holder

The length of the downpipe depends on the type of termination chosen. Remember that the downpipe must extend at least 50 mm into both the upper edge (in the pipe bend) and the lower edge (in the ejector). In push pipes or drain shoes, the downpipe must go in about halfway.

If the downpipe is not to be joined with another downpipe, the tapered edge must be sawn off when cutting.

Different types of pipe holders

- SVHA, with wedge lock. Can also be combined with SST pins for fastening in brick and plaster facades.
- SSVU, which is self-locking (snap-on holder). Can also be combined with SST pins for fastening in brick and plaster facades.
- Can also be combined with SSC pins for fastening in concrete and lightweight concrete.
- SHFS, for fastening in brick and plaster facades.
- SHFB, for fastening in wooden facades.

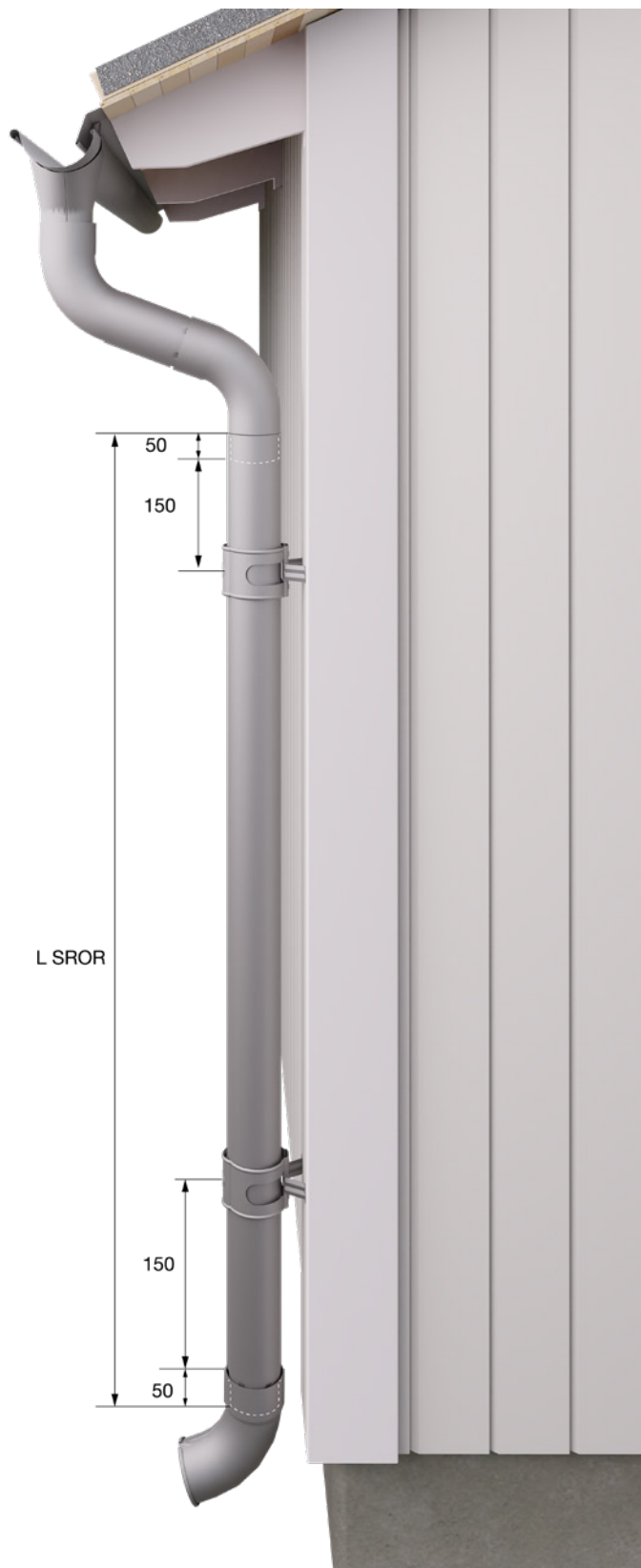

Positioning of pipe holder

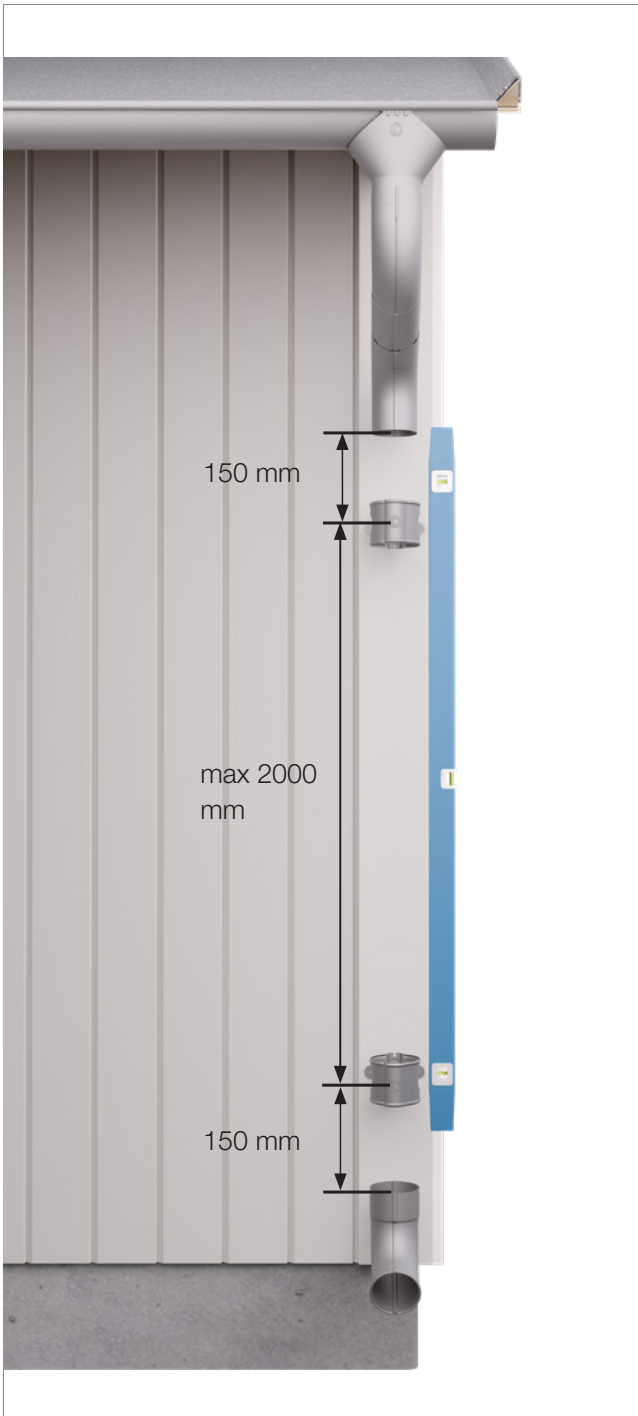

The pipe holder should be positioned approx. 150 mm below the bottom edge of the bottom bend.

The height of the bottom needs to be adapted to the type of termination used. Bear in mind that if screens are used, they must be able to be cleaned, and it must be possible to pull up the drain shoe or push pipe a bit.

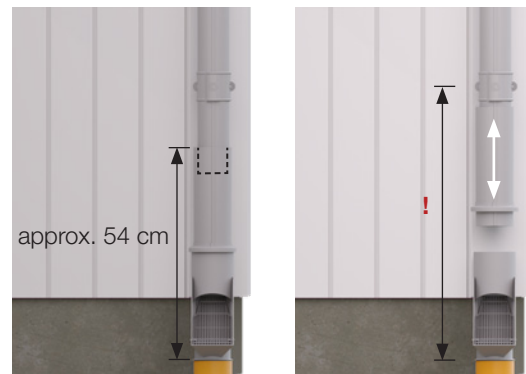

When the SLS leaf screen with hopper and BUTK drain shoe are used, the bottom holder must be positioned so that BUTK can be pushed up during cleaning - approx. xx cm from the top edge of the ground drain pipe.

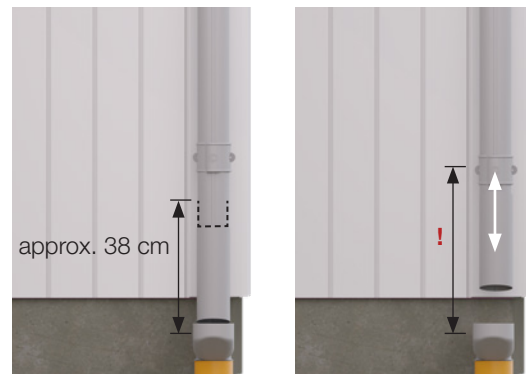

When the drain trap RT and push pipe PRT are used, the bottom holder needs to be placed so that the PRT can be pushed up during cleaning - approx. xx cm from the top edge of the ground drain pipe.

5. Installation of pipe holders

Pipe holder SSVU installation against brick or plastered facade

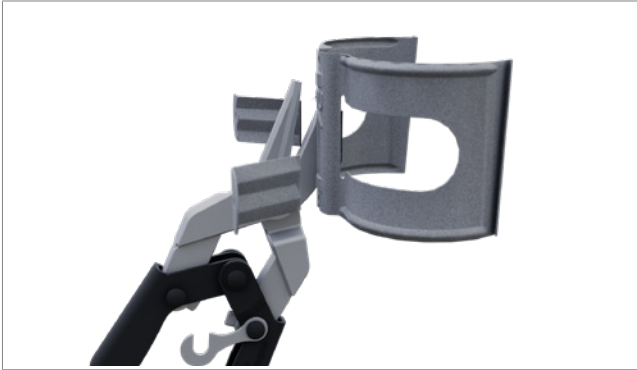

If pipe holder SSVU is to be used in combination with pin SST or screw SSC, the legs on the holder are cut off.



Drill - with a slight upward slope - an 8 mm hole in the joint for pins or screws.



Hook the pin in at the bottom edge of the cover and then twist it into place.



Nail the pin into the pre-drilled hole.

Pipe holder SSVU in combination with pin SSC



Nail the plug into the pre-drilled hole.



Place the spacers behind the holder and then screw the holder in place.

Pipe holder SSVU installation on wooden facade

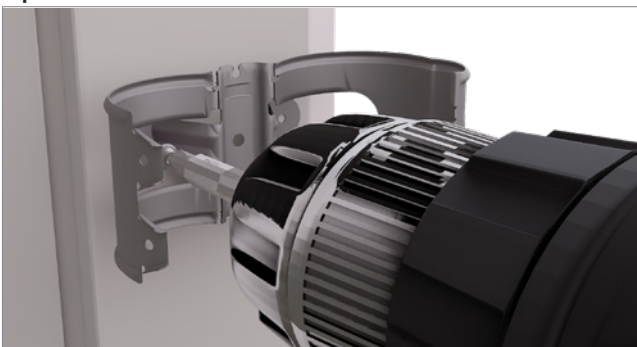

Open the clamps and screw the pipe holder in place with a wood screw (not included).

Locking of pipe holder SSVU



Position the downpipe (with the seam facing outwards). Squeeze the pipe holder together so that the two brackets snap into each other.



First press on one edge...



... and then at the other edge so that the holder locks.

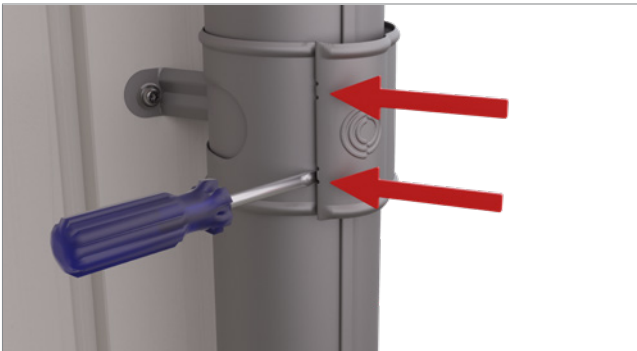

To open the holder again, use a flat screwdriver.

Pipe holder with wedge lock SVHA - installation in combination with pin SST on brick facade

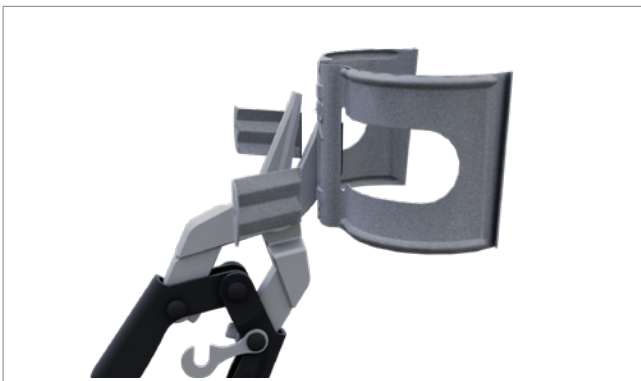

If pipe holder SVHA is to be used in combination with SST pins, the legs on the cover are cut off.



Drill -slightly inclined upwards- an 8 mm hole in the joint for the pin.



Hook the pin in at the bottom edge of the cover and then twist it into place.



Nail the pin into the pre-drilled hole.

Pipe holder with wedge lock SVHA - installation on wooden facade

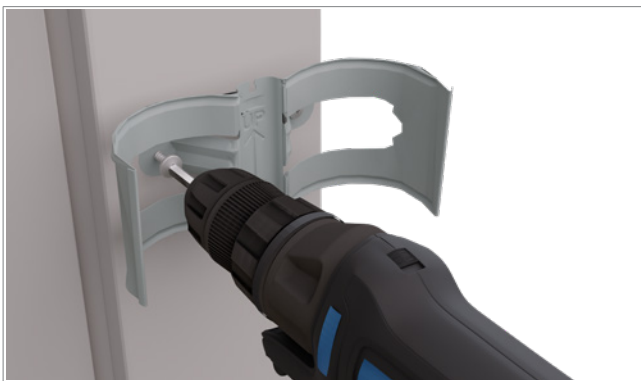

Open the clamps and screw the pipe holder in place with a wood screw (not included).

Locking of pipe holder SVHA



Position the downpipe and squeeze the clamps together.

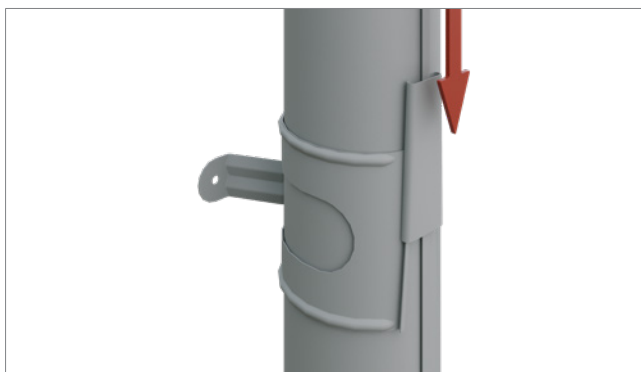

Press the wedge lock down over the joint. It may be necessary to use a plastic mallet to get the wedge lock all the way down to the bottom, but use a shim if necessary.

Pipe holder SHFS installation on brick facade



Drill -slightly inclined upwards- an 8 mm hole in the joint for the pin.

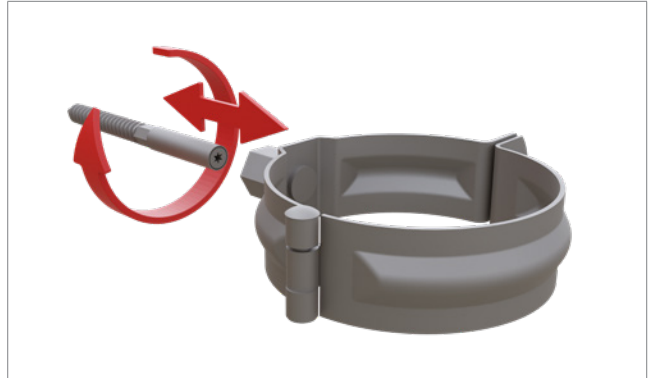

Unscrew the pin from the holder.



Screw the stud screw into the brick wall.



Screw back the holder on the stud screw.

Pipe holder SHFB installation on wooden facade



Screw the pipe holder in place with a wood screw (not included).

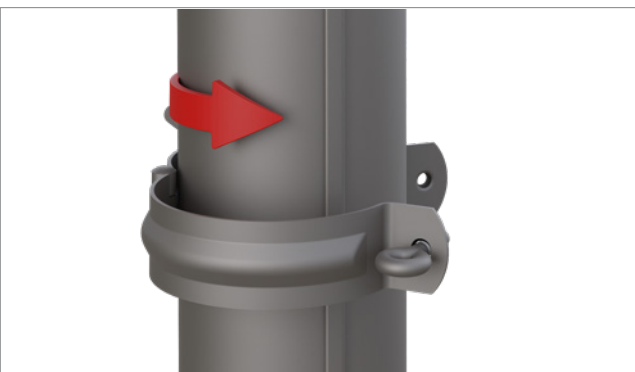

Open the clamp with the locking screw, position the downpipe and close the holder.

6. Drainage and collection of water

One important thing to consider is to lead the collected water away from the house - both for the house itself and for the ground around it. For this purpose, there are different types of solutions, all starting with the selection of the drain shoe. The simplest drain shoe is the downpipe end shoe, which basically only directs the water out of the house. Here, you should prepare the ground underneath either with stone laying that leads the water onwards, or with another alternative.



Bends, end shoes and downpipes are always fitted with the seam facing out from the house. This is to prevent the pipe from leaking water into the facade in the event of frost damage.

Downpipe end shoe UTK

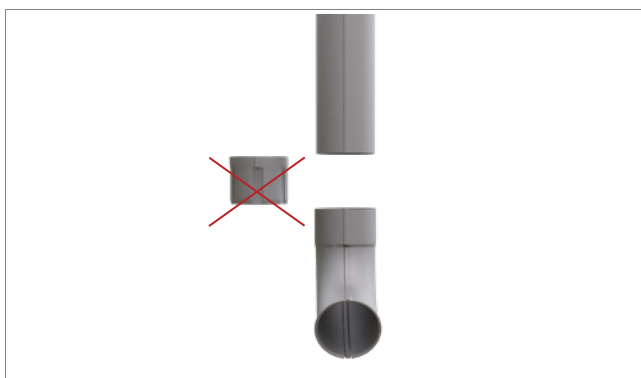

When installing with downpipe end shoe UTK, the tapered part of the downpipe must be removed.



Downpipe end shoe UTK can be fastened with a screw on the back.

Drain shoe BUTK with storm water strainer DVSIL



A BUTK drain shoe is connected to an unenclosed ground drain pipe.



The BUTK drain shoe is easily moved up the downpipe. The drain shoe is supplemented with a leaf strainer to prevent blockage of the ground pipe. A DVSIL storm water strainer is hidden inside the ground pipe. Bear in mind that the bottom pipe holder must be high enough to be able to move the BUTK up and lift out the strainer for cleaning.

Drain trap RT with push pipe PRT

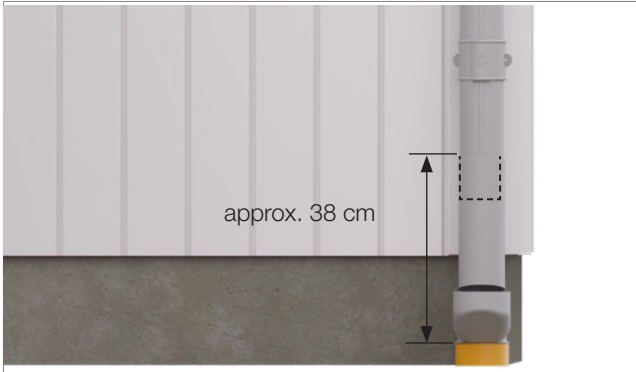

A BUTK drain shoe is connected to an unenclosed ground drain pipe. The drain trap is combined with a push pipe to facilitate cleaning.



The push pipe PRT is easily guided up the downpipe. Be aware that the bottom pipe holder needs to be high enough to be able to move the PRT up for cleaning.

Self-cleaning leaf strainer SLS with drain shoe BUTK

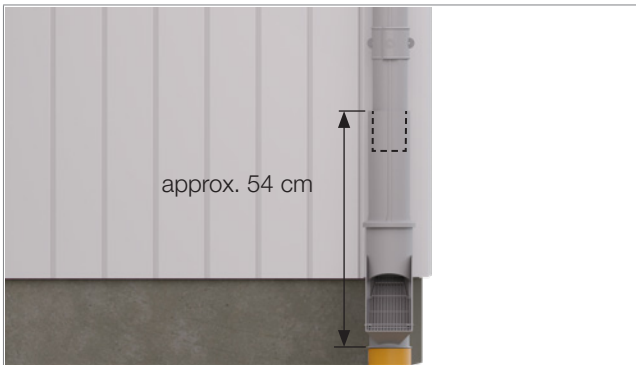

A self-cleaning leaf strainer SLS is connected to an unenclosed ground drain pipe and combined with a drain shoe BUTK.



The BUTK drain shoe is easily moved up the downpipe. Bear in mind that the bottom pipe holder needs to be high enough for BUTK to be moved up for cleaning.

Underground pipe cladding IMR



In order to conceal a ground drain pipe, the IMR underground pipe cladding can be used. Fits unenclosed ground drain pipe and is 30 cm long. The IMR is easily threaded onto the ground drain pipe.



Fold out shoe FUTK

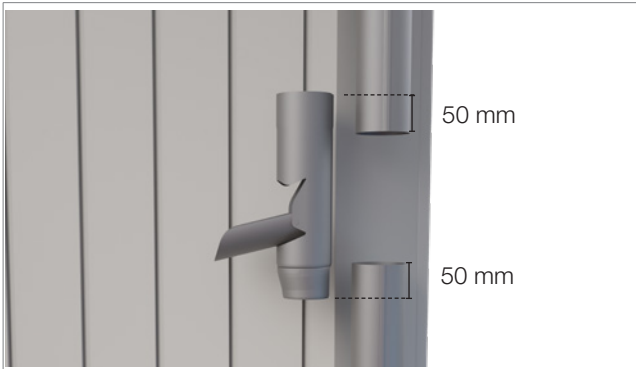

A fold-out shoe can be used for e.g. a rain barrel. When installing with FUTK, the tapered part of the downpipe must be removed.

Branch pipe GROR

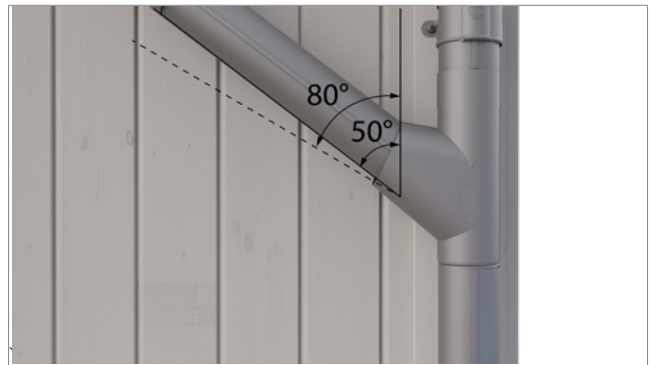
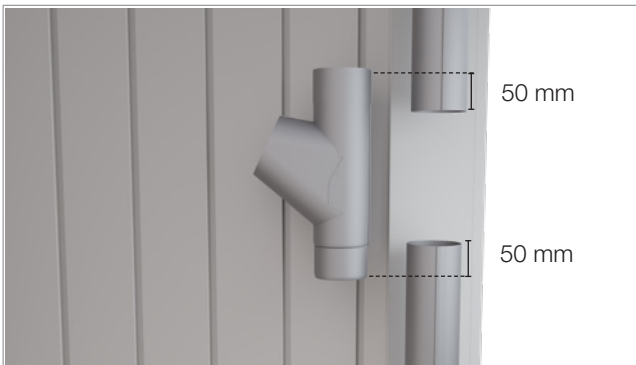

Branch pipes can be used to connect two separate gutters to one downpipe. When installing with GROR, the tapered part of the downpipe must be removed.

The downpipe can be angled from 50-80° from the vertical plane.

One-piece bend SOKN



As the facade has different levels, a one-piece bend can be used. When installing with SOKN, the tapered part of the downpipe must be removed.

Other products

Overflow protection for inner angle

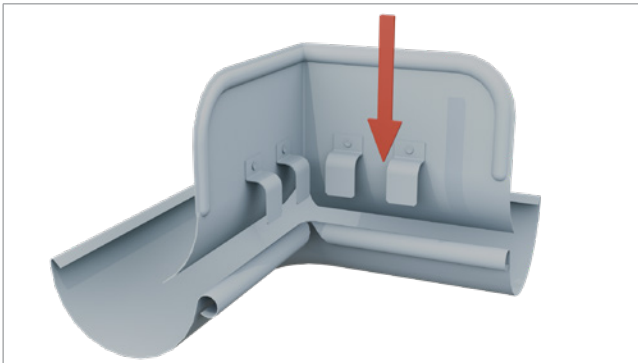

Slide the overflow protection onto the gutter angle.

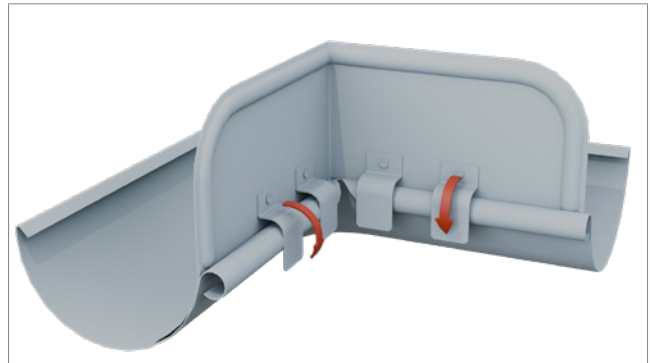

Fold the clamps around the bead of the chute.

Straight overflow protection



Slide the overflow protection up under the inner edge of the gutter and press the brackets down over the bead of the gutter.

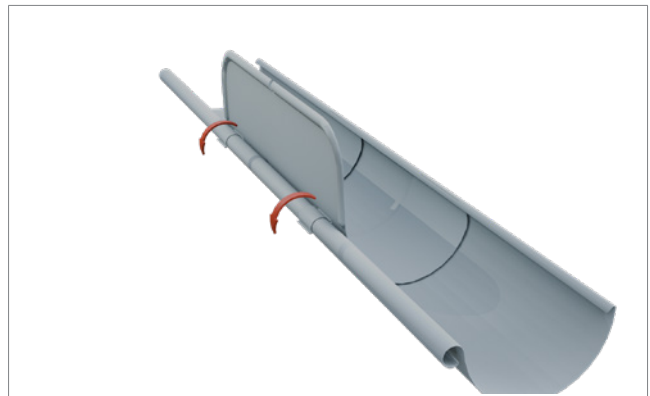



Most of us spend the majority of our time indoors. Indoor climate is crucial to how we feel, how productive we are and if we stay healthy.

We at Lindab have therefore made it our most important objective to contribute to an indoor climate that improves people's lives. We do this by developing energy-efficient ventilation solutions and durable building products. We also aim to contribute to a better climate for our planet by working in a way that is sustainable for both people and the environment.

[Lindab | For a better climate](#)